

K.D. LOCKER

ASSEMBLY INSTRUCTIONS

These Instructions Cover 3 Types of Lockers: VANGUARD, GUARDIAN AND INVINCIBLE II

General Instructions	1
Major Locker Components	2
Hardware and Small Locker Parts	3
Basic Assembly Single Row Lockers	4-6
Installing Coat Rods	4
Guidelines for Rear Leg Spacing	4
Defiant II Locker: Assembly of Anti-Pry/Twist Bracket	5
Hook and Coat Rod Guidelines	6
Multi-Tier Lockers	7
Two Person/Duplex/Dual Lockers	7
Individual Closed Bases	8
Zee Base	8
Unit Slope Tops, Slope Top Kits, Continuous Slope Hoods	9
16 Person and Wall Mounted Lockers	10
Invincible II Group End Kits	11

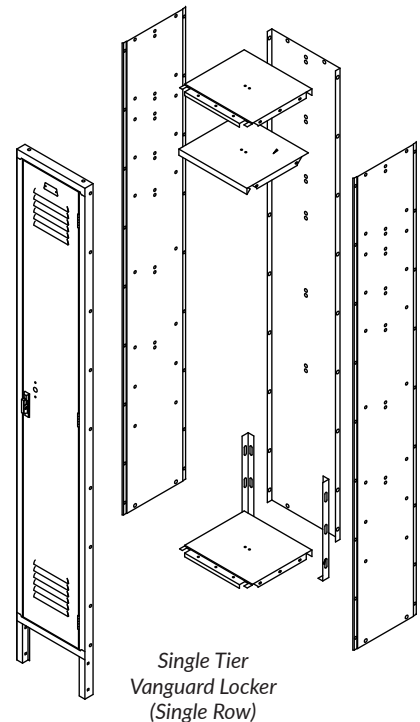

GENERAL INSTRUCTIONS

1. These instructions are for the person who will actually perform or supervise the assembly of the lockers.
2. Check material received against the packing list. First check the number of packages received and then check the contents of each package.
3. Check material received for damage. If any of it is damaged, secure a "damage notation" from the carrier.
4. Identify each part as it is unpacked and put like parts together as close as possible to the working area in which they are to be assembled.
5. Be careful to use the correct hardware as specified in the assembly instructions.

CAUTION

It is the responsibility of the persons assembling the lockers to properly install all components and hardware as specified in these instructions and any accompanying drawings for specific installation.

- INSTALL ALL UNITS PLUMB
- TIGHTEN ALL HARDWARE SECURELY

MAJOR LOCKER COMPONENTS For 1,2,3,4,5,6 TIER AND MULTI-TIER DOORS

Flat Top Locker Body Parts

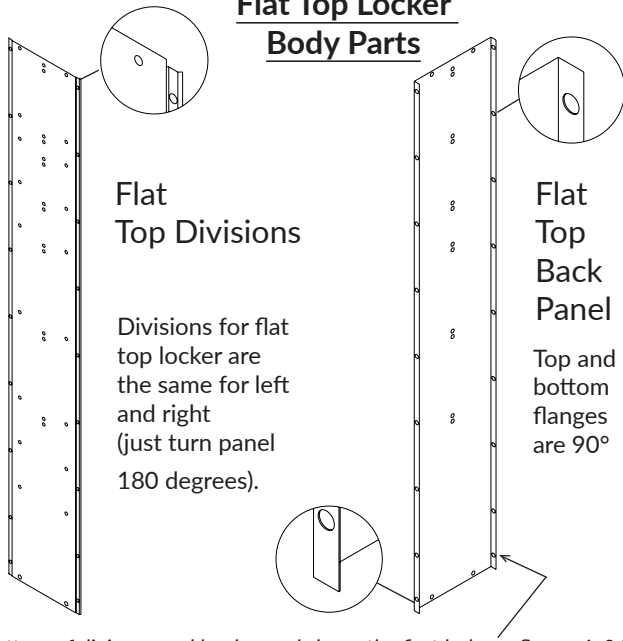

Slope Top Locker Body Parts

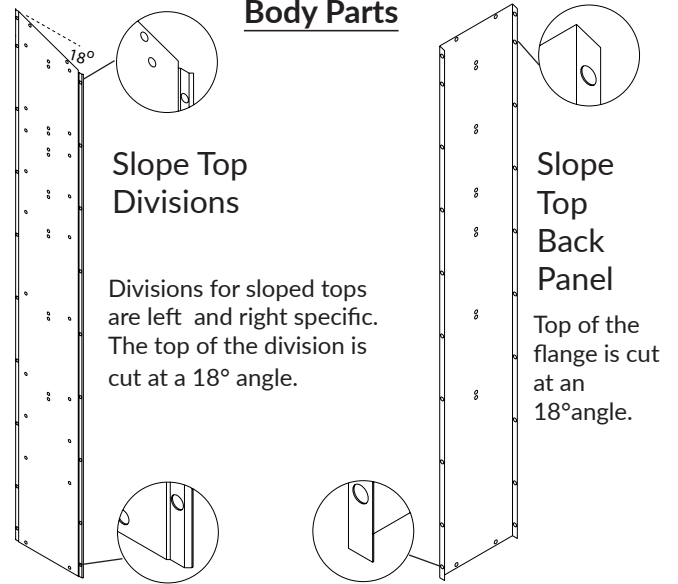

Bottom of divisions and back panels have the first hole on flange 1-3/4" from edge, (top of divisions and back panel have the first hole 1-1/4" from edge).

Examples of Locker Door and Frame Assemblies

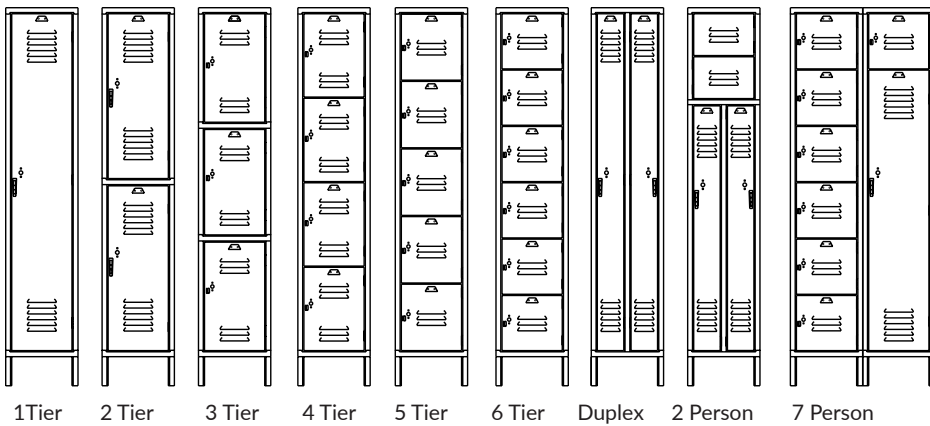

2 Person, Dual and Duplex Parts

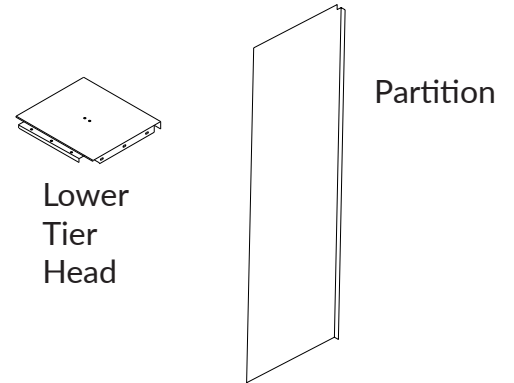

Divisions for Double Row Lockers

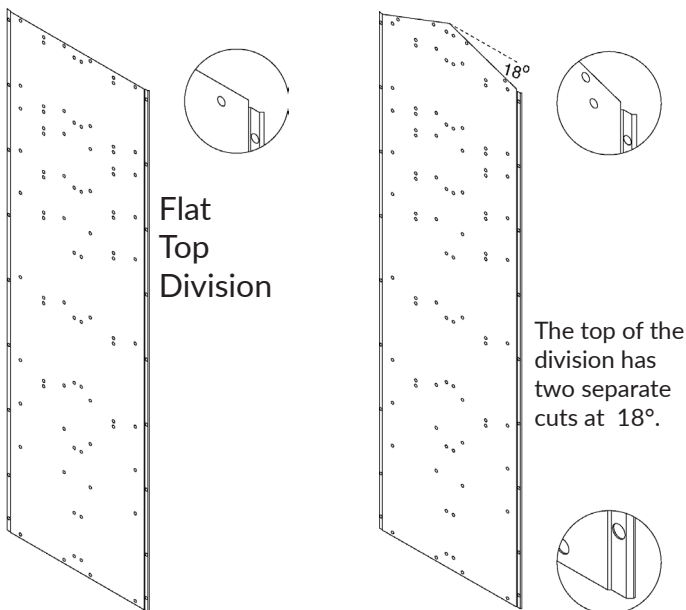

Locker Tops, Bottom (T.A.B.) and Shelves

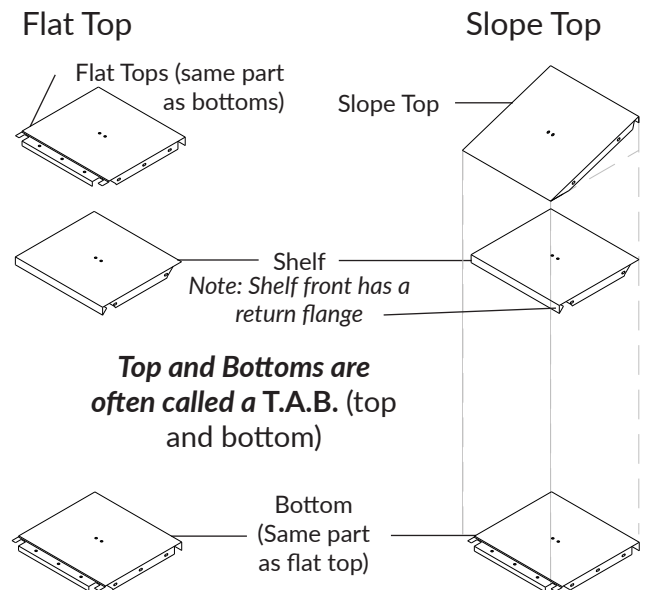

Single row lockers must be floor and wall anchored.

HARDWARE AND SMALL LOCKER PARTS

Not all parts come with all lockers. Check packing list for what parts are to be used with what models of lockers.



Number Plate and Rivet
To be riveted to top of locker door.



Single Prong Wall Hook
To be bolted to divisions and to back panel.

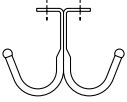

Single & Double Prong Ceiling Hook
To be bolted to bottom of shelf or top of

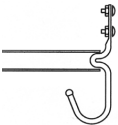

Coat Rod Hooks with Rod
Hooks to be bolted to divisions with coat rod in between, used in single tier, Duplex, 2,7,8 person and Dual lockers 18" or more in depth.



Hook Clip
Used to attach single prong wall hooks and coat rod hooks in lockers with Diamond Perforated divisions at ends only.

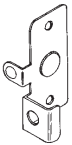

Door Pull
Used on box locker door unless a built-in lock is used. To be mounted on inside of door with pull tab inserted through vertical slot in door.

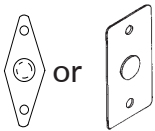

Lock Hole Cover Plate
Used to cover hole in door when built-in locks are not used. To be mounted on inside of door.

Nuts and Bolts

10-24 x 3/8" Truss fin head bolt and nut for assembly of Vanguard locker body parts. Tighten nut with a wrench or nut driver. (bolt is tamper resistant so it has no slot for a screw driver)

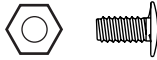

10-24 x 1/2" Truss fin head bolt and nut for assembly of the entire Invincible II locker. In the Vanguard locker this nut and bolt is used in joining locker groups, locker legs and 2 hooks with the partition between the hooks. Tighten nut with a wrench or nut driver (bolt is tamper resistant so it has no slot for a screw driver)

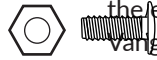

NO. 8 x 3/8" Sheet metal screw for slope tops only.

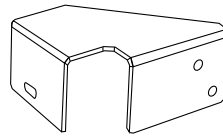

Bracket Support (Defiant II)
Strengthens locking point on Defiant II lockers. Bolts to Defiant II hasp and to side of locker.

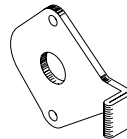

Anti-Pry / Lock Alignment Bracket (Defiant II) Used on back of recessed pocket in Defiant II Lockers (Single Point Latch).

Optional Items That are Ordered Separately from Locker



Combination Padlock (9/32" or .281" Shackle)
Used to secure locker door when built in lock is not used. Lock may come from another supplier other than Penco Products.

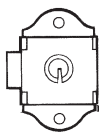

Built-in Key Lock
Used to secure locker door when padlock is not used. This lock replaces Lock Hole Cover Plate or Door Pull. To be mounted on inside of door. Lock may come from another supplier other than Penco Products.



Locker Shoe
Can be used on the front legs of locker to secure to floor. Protects floor along with leveling lockers on an uneven floor.

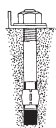

Concrete Floor Anchor
1/4 x 2" Used to secure locker to a concrete floor. Bolt type will vary with floor type.

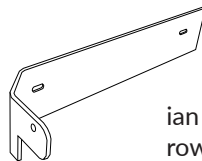

Side Stiffener (Defiant II Guardian Doors Only)
When built-in locks are used on Defiant II Guardian Lockers (24 gauge side panels), the last locker in a row of lockers, is to have a Side Stiffener bolted to the Defiant II lock hasp and side of locker (replaces Bracket Support if built-in lock are used).



Built-in Combination Lock
Used to secure locker door when padlock is not used. This lock replaces Lock Hole Cover Plate or Door Pull. To be mounted on inside of door. Lock may come from another supplier other than Penco Products.



Safe-O-Mat Coin Operated Lock
Used to secure locker door when padlock is not used. This lock replaces Lock Hole Cover Plate. Lock engages when token or coin is deposited.



Touch Up Paint
Used to touch up paint finish (21 standard colors).

Single row lockers must be floor and wall anchored.

BASIC ASSEMBLY OF SINGLE ROW LOCKERS (A Grouping of 3 Single Tier Lockers Illustrated)

Operation 1

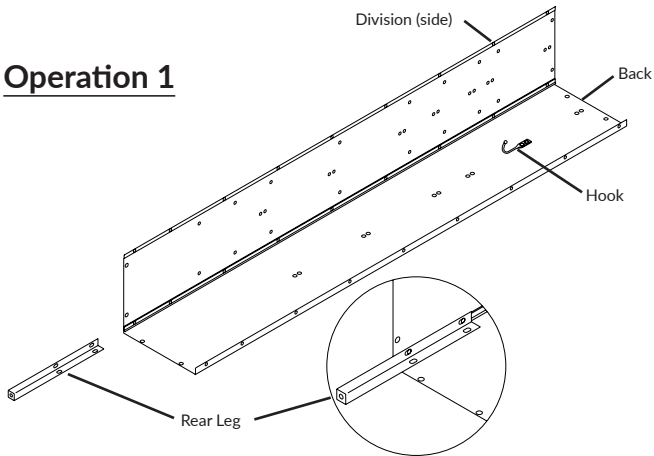

- A. Bolt hook to back. (Vanguard uses 10-24 x 3/8" truss fin bolts for body parts unless noted, Invincible II uses 10-24 x 1/2" truss fin head bolts for entire locker).
- B. Place division inside the back and bolt together. If legs are required, use 10-24x1/2" bolts to fasten legs at the bottom.

NOTE: Hook type and placement varies with locker size and style. Refer to the table called **Hook and Coat Rod Guidelines** on

Operation 2

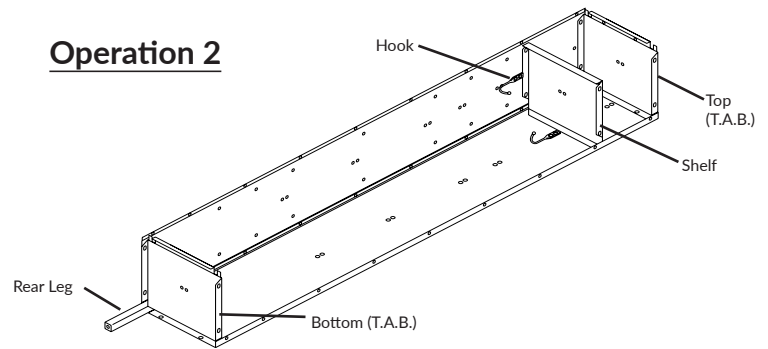

page 6.

- A. Bolt top (T.A.B.), shelf, side hook and bottom (T.A.B.) to back and division (flat top and bottom are same part).
- NOTE: If assembling a Multi-Tier, Two Person, Duplex or Dual Locker, refer to the section on page 7, **Multi-Tier, Two Person, Duplex and Dual Lockers** to complete Operation 2. For Coat Rod Instal-

Operation 3

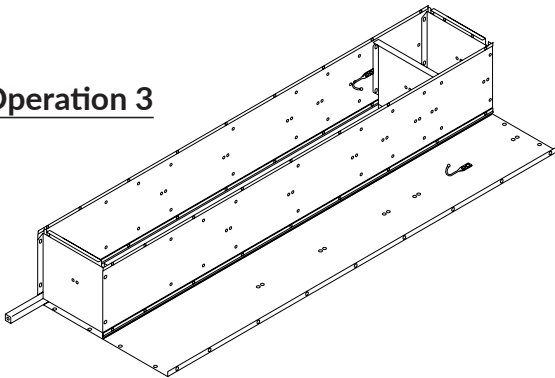

- ation see page 4, **Installing Coat Rod.**
- A. Bolt hook to second back.

Operation 4

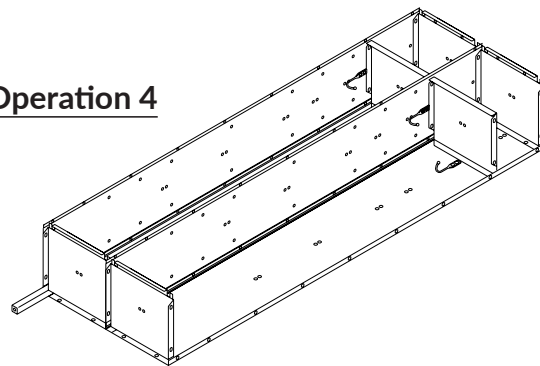

- B. Bolt second back and second division to first back.
- A. Bolt second set of tops (T.A.B.), shelves, 2 hooks and bottoms (T.A.B.) to back and division. If coat rods are required install in first locker.
- B. Continue as in Operations 2 through 4 until desired number of units for the group are assembled, then proceed to Operation 5.

Installing Coat Rod

(Add this step to Operation 2), before installing top (T.A.B.) and shelf, install coat rod hooks on the inside of divisions and (or) both sides of partition using the same bolt (where possible). Spread apart division and (or) partition and then insert coat rod into coat rod holder on coat rod hook.

Guidelines for Rear Leg Spacing for Single Row Lockers

IMPORTANT: If lockers have been ordered with grouping specified, assemble lockers as ordered. Back legs should not exceed 45" distance between legs. If grouping has not been specified assemble lockers using the chart.

Width of Single Locker (inches)	7-1/2"	9"	12"	15"	18"	24"
Lockers in a Single Row Grouping	9	8	7	6	4	3
Back Legs in Each Grouping	9	6	5	4	3	2

Single row lockers must be floor and wall anchored.

Operation 5

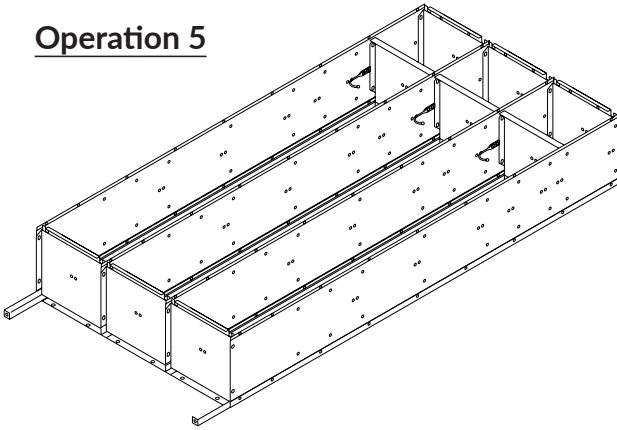

- A. Place second leg in position (between bottom and back). Distance between back legs not to exceed 45 inches.
 - B. Place end division in position and bolt to top, shelf, hook, back leg and bottom (use 10- 24 x 1/2 bolts for leg).
- NOTE: Invincible II Lockers Only see page 12 regarding group ends.**
- C. Bolt a double prong hook to each shelf (if supplied).

Operation 6

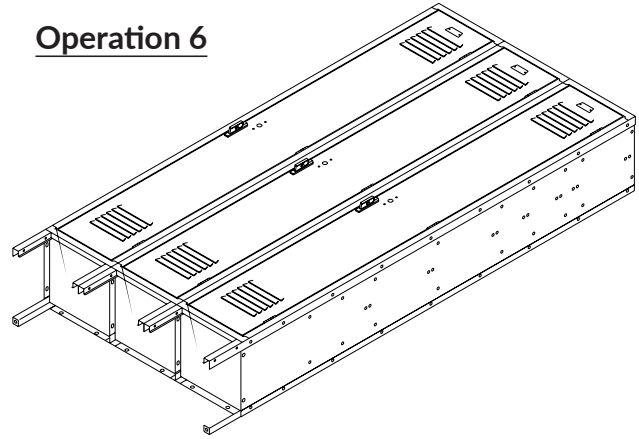

- A. Place door and frame assemblies in position with the top, bottom and end divisions inside the door frames and bolt to divisions, top and bottoms (T.A.B.). If two or more groups are to be joined in a row, omit bolts thru joining door frame and divisions.
- If locker has a Defiant II Door (Single Point Latch) go to Operations 6B and 6C. All other door types proceed to Operation 7 on next page.**
- If Closed Bases are being used refer to Closed Bases on page 9.
- If grouping has not been specified, assemble lockers using the **Guidelines for Rear Leg Spacing** on page 4.
- IMPORTANT:** When using locks do not close door unless you have keys or combination.

Operation 6B Defiant II Doors Only

1 and 2 Tier Defiant II Doors Only (single point latch) use 2 bolts to mount bracket support to lock hasp and one bolt to side panel. If built-in locks are to be used on the left hand end of a row and the locker has light gauge side panels replace the bracket support with a side stiffener (see page 3).

Operation 6C Defiant II Doors Only

1. Locate the Anti-Pry / Lock Alignment Bracket, Locks (if ordered), Lock Hole Cover Plates and 3/8" long locker screws (if built-in combination locks are NOT used) and nuts.
- 2A. If combination locks are being installed, place the Anti-Pry / Lock Alignment Bracket on the back side of the recessed pocket first, followed by the back of the lock unit as shown in the drawing. Insert the combination dial mechanism in the front of the pocket, and attach with 2 nuts.
- 2B. If built-in locks are NOT being used, place the Anti-Pry / Lock Alignment Bracket on the back of the recessed pocket first, followed by a Lock Hole Cover Plate as shown in the drawing. Fasten with 3/8" locker screws and nuts.

Note: Tighten nuts only finger tight at first. This will allow the bracket to stay in place during the next step of adjusting the bracket, but not restrict the bracket's movement in to proper alignment.

3. Close the door. As the door is closed, the bracket will enter into the hasp and slide into its proper alignment.

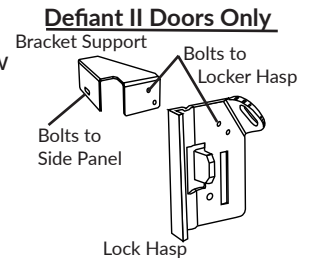

Open and close the door once or twice more to check alignment. A door with a properly aligned bracket will open and close smoothly with only a little resistance between bracket and friction catch.

4. Once the bracket is aligned, tighten the nuts using a 3/8" nut driver. Use care not to move the bracket out of alignment while tightening nuts. Open and close the door to check that alignment is unchanged.

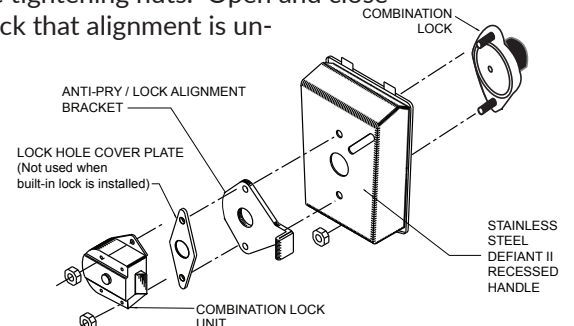

Single row lockers must be floor and wall anchored.

Operation 7

Optional: If connecting groups order additional hardware.

- Set groups in place.
- Use 10-24 x 1/2 bolts to bolt joining door frames and backs of each locker group.
- Rivet number plates to top of doors.
- Bolt built-in locks or door pulls or lock hole cover plates to inside of door.
- Adjust doors and latches to operate without binding. Verify that latches are operating satisfactorily.
- Part numbers needed: 8633H(100 bolts), 8672H(100 MTS) for QuickShip KIT8633/72-HKIT (100 EA.)

Top View of Two Groupings of Three Lockers

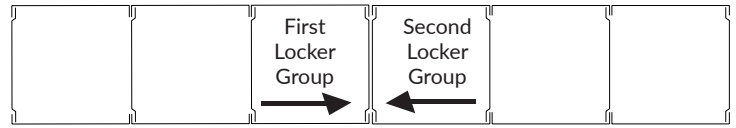
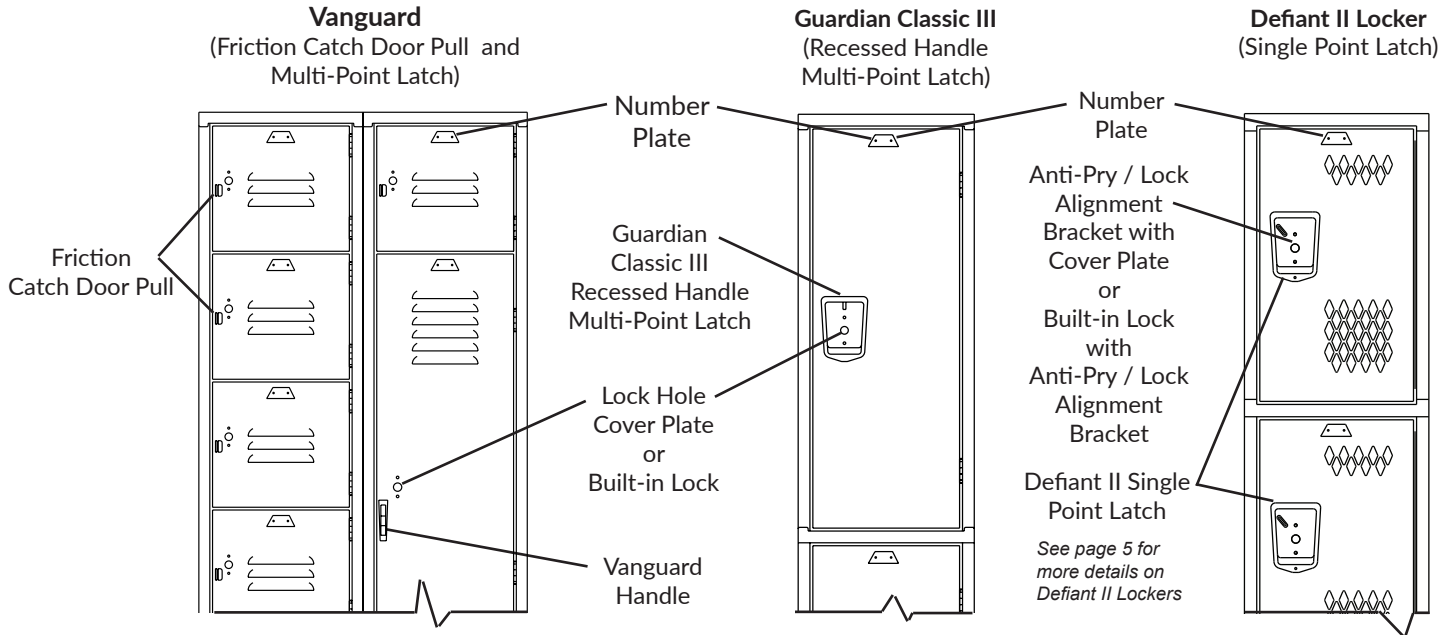

Illustration of Number Plate, Lock Hole Cover Plate or Built-in Locks Positioning



Hook and Coat Rod Guidelines

Number of Pieces Supplied per Locker FRAME * - Standard Construction Only

	1 Tier	2 Tier	3 Tier	4,5,6,8,9 Tier	2 Person	7 Person	8 Person	16 Person	Duplex	Dual
Single Prong Hooks										
Depth Less than 18" AND:										
... Width less than 15"	3	6	9	-	n/a	n/a	n/a	n/a	n/a	4
... Width =15" or more	4	8	12	-	4	n/a	n/a	n/a	4	4
Depth 18" or more AND:										
... Width less than 15"	1	6	12	-	n/a	-	-	n/a	n/a	-
... Width =15" or more	2	8	12	-	-	-	-	n/a	-	-
Double Prong Hooks										
Depth 18" or more	-	-	-	-	-	-	-	-	-	-
Depth LESS than 18" AND:										
... Width is LESS than 21"	1 **	2	-	-	-	n/a	n/a	n/a	-	-
... Width is 21" or more	2	4	-	-	n/a	n/a	n/a	n/a	n/a	-
Coat Rod Hooks										
Depth Less than 18"	-	-	-	-	-	n/a	n/a	n/a	-	-
Depth 18" or more	2	-	-	-	4	2	4	-	4	4
Coat Rods										
Depth Less than 18"	-	-	-	-	-	n/a	n/a	n/a	-	-
Depth 18" or more	1	-	-	-	2	1	2	1	2	2

n/a: Not Applicable in Standard Construction

* Exceptions: 7, 8 & 16 Person quantities are for entire unit.

** Exception: Single Tier 9" wide x 15" deep has NO Double Prong Hooks

Single row lockers must be floor and wall anchored.

MULTI-TIER / TWO PERSON/DUPLEX AND DUAL ASSEMBLY INSTRUCTIONS

Assemble lockers using the Single or Double Tier Instructions, during **Operation 2** add the appropriate shelf, top, bottom or partition.

Shelf Spacing Guidelines

Single tier lockers have a shelf approx. 9" below the top of the locker.

For **Multi-tier** locker take the height of the locker and divide the number of doors to get shelf spacing.

Example: *Height 72", Number of Doors 6, $72"/6 = 12"$ distance between shelves.*

Locker doors and frame can also be used as a template for shelf or flat top (T.A.B.) positioning.

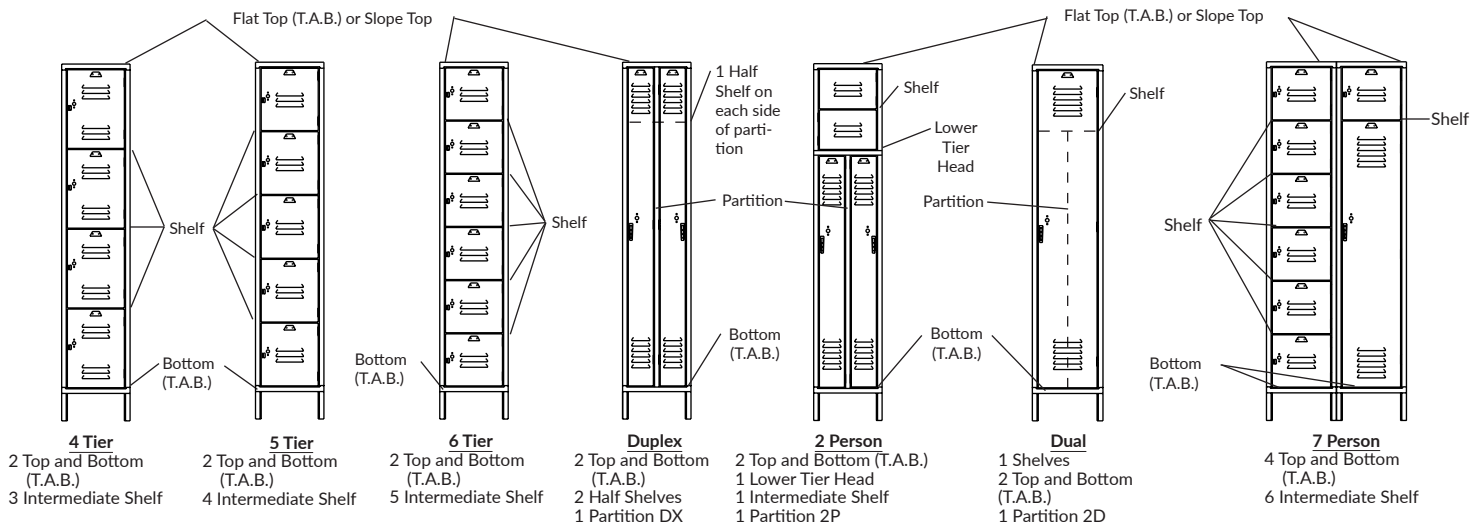
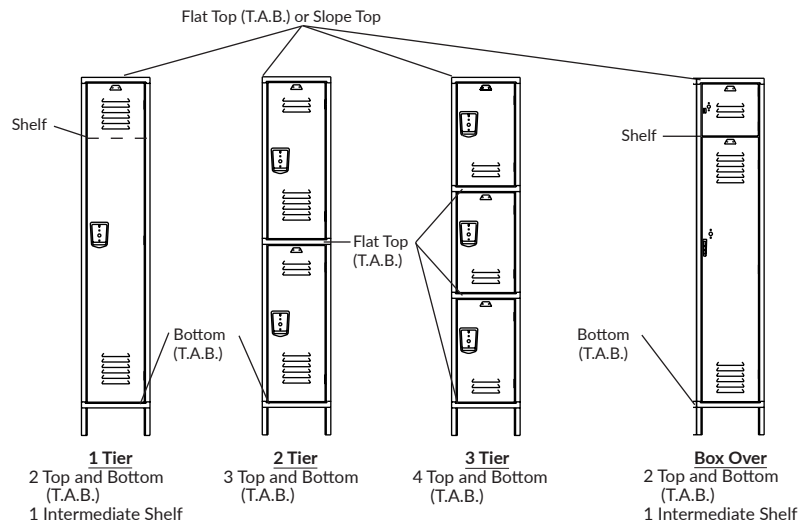

The hole punching pattern on Divisions are the same for all lockers except for 5 Tier Lockers and 16 gauge Exposed End Panels.

2 PERSON, DUPLEX AND DUAL LOCKER SUPPLEMENTAL INSTRUCTIONS

2 Person Bolt bottom (T.A.B.) to bottom of back and division. Bolt partition to bottom (T.A.B.). Bolt a Lower Tier Head to top of partition and divisions. Then bolt shelf above the top of partition. Bolt coat hooks on the inside of divisions and both sides of partition using the same bolt (where possible). Place top (T.A.B.) at top of locker and bolt to back and divisions. Proceed to Operation 3 of Assembly of Single Row or Double Row Lockers.

Dual Bolt bottom (T.A.B.) to bottom of back and division. Bolt partition to bottom. Install coat rod hooks on the inside of divisions and both sides of partition using the same bolt (where possible). Spread apart partition and division and insert coat rod into coat rod holder on coat rod hook. Place bottom of the shelf against top of partition and bolt to divisions. Place top (T.A.B.) at top of locker and bolt to back and divisions. Proceed to Operation 3 of Assembly of Single Row or Double Row Lockers.

Duplex Bolt bottom (T.A.B.) to bottom of back and division. Bolt partition to bottom (T.A.B.). Bolt 2 half shelves to each side of partition and divisions. Bolt coat hooks on the inside of divisions and both sides of partition using the same bolt (where possible). Place top (T.A.B.) at top of locker and bolt to back and divisions. Proceed to Operation 3 of Assembly of Single Row or Double Row Lockers.

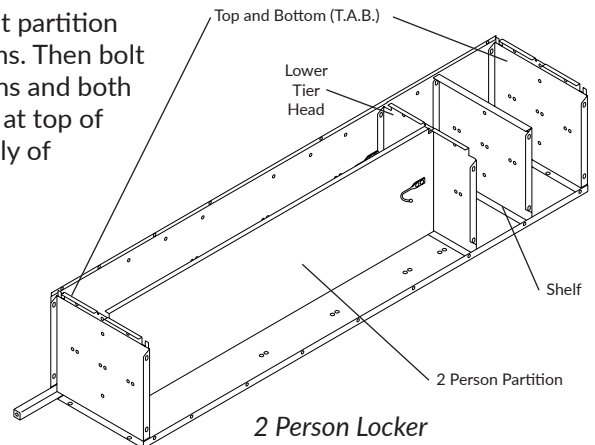

Single row lockers must be floor and wall anchored.

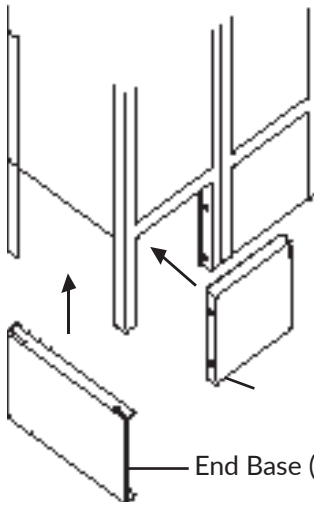

INDIVIDUAL CLOSED BASES

Front and end bases are designed to fit between standard Penco 6" legs. The front base snaps in between the front legs. The end base slips over legs during locker assembly.

1. Before standing locker up and placing the locker in position, slide the End Base up the leg of the end of the locker row.
2. Stand locker up and put the lockers in proper position.
3. Snap Front Base between the front legs of each locker so that the two extruded tabs on either side of Front Base match up with the square slots in the front legs.

ZEE BASE: for lockers to be anchored to wall

Zee Base raises lockers without legs off the floor and provides a continuous closed base. It is used when there is no concrete or wood base. Available in lengths of 72" only, the Zee Base shall be cut by installer when shorter lengths are needed.

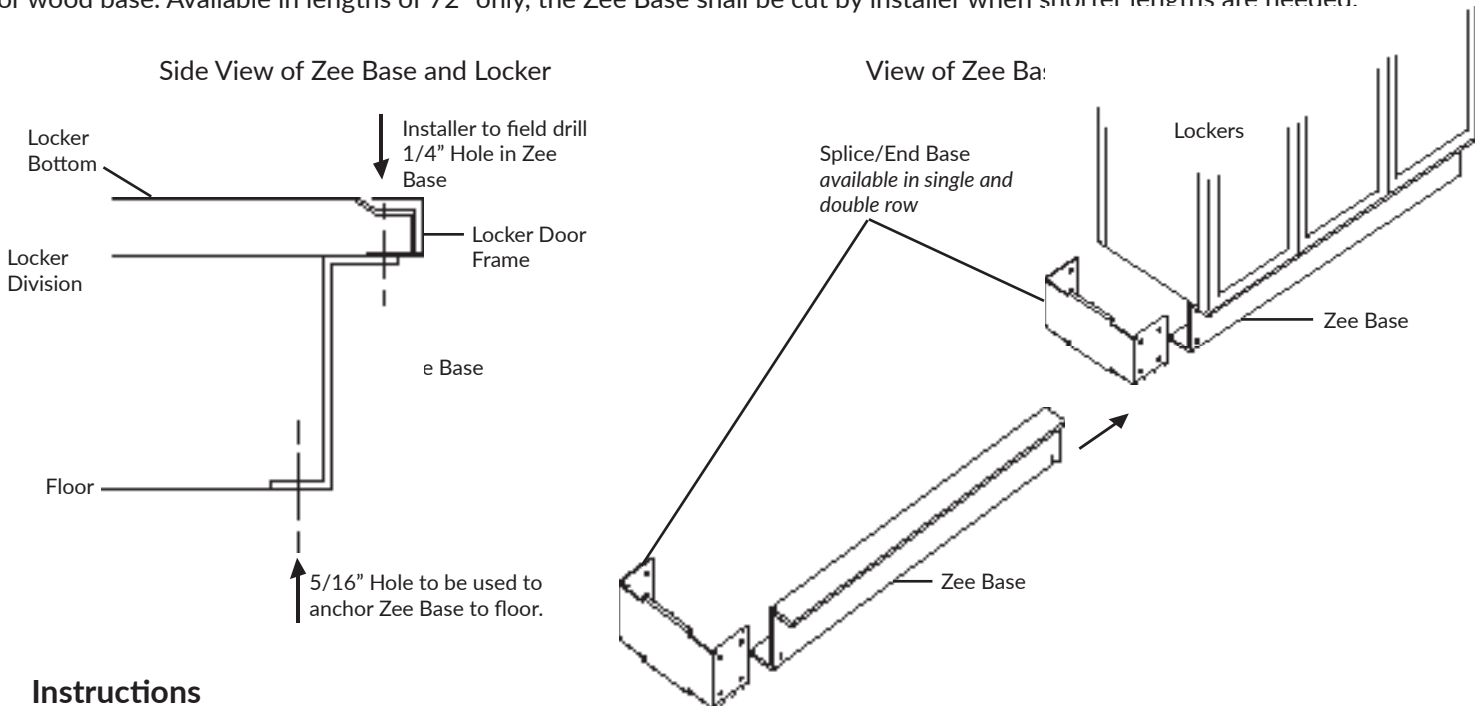

Instructions

1. Match Zee Bases and Splice/End Bases to lockers, site plan and installation location.
2. Use Splice/End Base as a template to position Zee Base.
3. Place Splice/End Base flush against wall (thinner side with holes) or create a chalk line as a positioning guide.
4. Create a chalk line for Zee Base positioning using Splice/End Bases as a measuring device.
5. Butt Zee Base against other side of Splice/End Base.
6. Measure locker depth and make sure Locker Door Frame will rest on Zee Base. (there should be a 1/4 inch space between the end of Zee Base and outside edge of Locker Door Frame).
7. Use the two sets of holes on the Splice/End Base to bolt together 2 lengths of the Zee Base.
8. Recheck measurements of Locker, Zee Base position, and site plans.
9. Anchor Zee Bases and Splice/End Base to floor with proper drill and bolt for the floor surface.
10. Assemble Single Row Lockers as per instructions on page 4 or assemble Double Row Lockers as per instructions on page 8 except when installing Door and Door Frame leave bolts at bottom of Door Frame off.
11. Place assembled locker on Zee Base (there should be a 1/4 inches space between the end of Zee Base and outside edge of Locker Door Frame).
12. Use the bottom hole of the Door Frame to position drill and drill a 1/4" hole through the top of the Zee Base.
13. Place bolt through Door Frame and Zee Base. Place nut on Zee Base side of bolt and tighten. Repeat steps 12 and 13 for each door.

Single row lockers must be floor and wall anchored.

Unit Slope Tops

Unit Slope Tops are used with Slope Top Divisions. One Unit Slope Top covers the width of one locker frame. (*Not for use on Invincible II or All-Welded lockers.*)

1. Open door to locker so you have access to top of locker.
2. Bolt unit slope top to divisions and back.
3. Insert sheet metal screws up the hole in the top of the door frame and fasten the front of the unit slope top to locker.
4. Repeat steps 1-4 as needed.

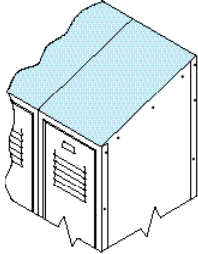

Unit Slope Tops			
Size (Inches)			Cat. No.
W	D	H	
9	12	-	80284C
9	15	-	80284C
9	18	-	80284C
12	12	-	80284C
12	15	-	80284C
12	18	-	80284C
12	21	-	80284C
15	12	-	803480C
15	15	-	80284C
15	18	-	80284C
15	21	-	80284C
18	18	-	80284C
18	21	-	80284C
18	24	-	80284C
24	18	-	80284C
24	21	-	80284C
24	24	-	80284C

Slope Top Kit

Designed to convert stock flat top lockers into slope top lockers in groups of 3 wide. Each Kit contains 3 tops, 3 backs and 4 ends. (*Not for use on Invincible II or All Welded lockers.*)

1. If there is a Flat Top (T.A.B.) on locker, remove bolts on sides and back.
2. Bolt Slope End to inside of locker.
3. Bolt Slope Back to outside of locker back and inside of Slope End.
4. Bolt slope top to sides and back.
5. Insert sheet metal screws up the hole in the top of the door frame and fasten the front of the slope top to locker.
6. Repeat steps 1-6 as needed.

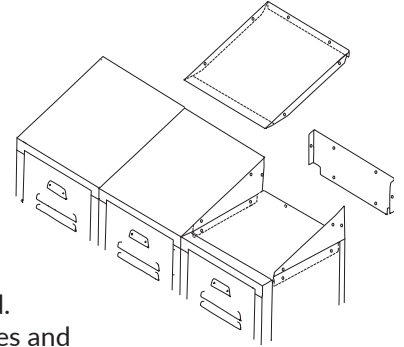

Slope Top Kits (3 wide kit)			
Size (Inches)			Cat. No.
W	D	H	
12	12	4	80220H
12	15	4	80220H
12	18	4	80220H
15	15	4	80220H
15	18	4	80220H

Continuous Slope Hoods

Continuous slope hoods fit on top of flat top lockers. They can be used on new lockers, or on a retrofit basis. All hoods are furnished in 72" lengths and must be cut to length during installation. Intermediate splices, ends and rear supports (2 per hood) complete the installation, and must be ordered separately.

Slope Hoods			
Size (Inches)			Cat. No.
W	D	H	
72	12	4	85144H
72	15	4	85147H
72	18	7	85150H
72	21	8	85153H
72	24	9	85156H

Size (Inches)		Slope Ends		Hood Splice	Universal Rear Hood Support
D	H	LH	RH		
		Cat. No.		Cat. No.	Cat. No.
12	5	85152H	85152H	85160C	85070 (one size fits all)
15	5	85153H	85153H	85160C	
18	7	85154H	85154H	85170C	
21	8	85154H	85154H	85171C	
24	9	85155H	85155H	85172C	

TYPICAL INSTALLATION

Slope Hood Detail with Optional Slope End Panels

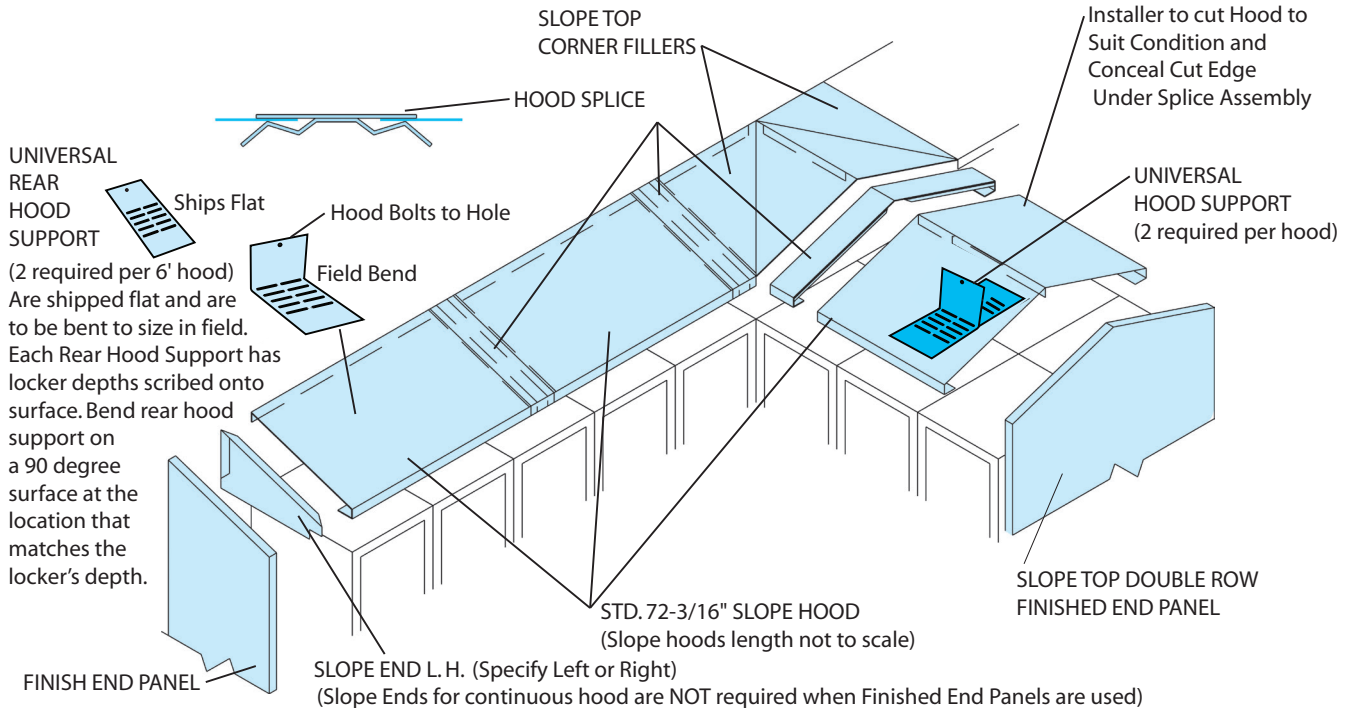

Single row lockers must be floor and wall anchored.



16 PERSON LOCKER ASSEMBLY INSTRUCTIONS

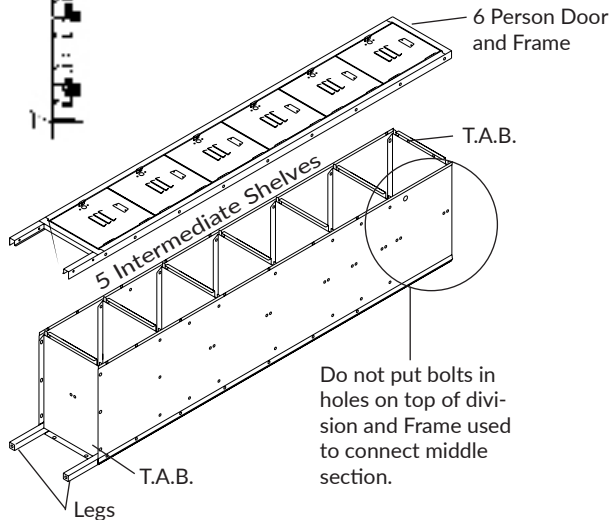

END SECTIONS

Assembly of Right Hand 6 Tier Locker

1. Bolt division (10-24 x 3/8 truss fin bolts) to right side of back. Bolt rear legs (10-24 x 1/2 tuss fin bolts and washer) to each side of back.
2. Bolt T.A.B. to bottom of division, back and add left division to back.
3. Bolt 4 bottom intermediate shelves to each division and back.
4. Bolt top intermediate shelf and T.A.B. (top) to right division and back. Leave bolts off left division so middle section can be joined.
5. Install door and frame assembly over divisions, top and bottom (T.A.B.) and bolt into place. Leave top two bolt holes empty on left side so middle section can be installed.

Assembly of Left Hand 6 Tier Locker

1. Assemble left side (6 tier locker) according to the above instructions but leave bolts off top of right division so middle section can be joined.
2. Install door and frame assembly over panels, top and T.A.B. and bolt into place. Leave top two bolt holes empty on left side so middle section can be installed.

MIDDLE SECTION

1. Separate flat 16 person top from bottom. The 16 person bottom has a larger front offset and no holes in offset.
2. Bolt three 16 person dividers to 16 person bottom.
3. Bolt 16 person top to 16 person dividers and back.
4. Place 16 person door and frame assembly over 16 person top and bottom's offset and bolt into place.

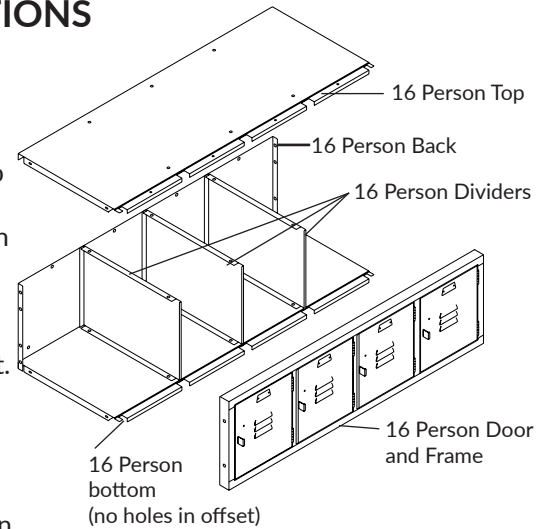

FINAL ASSEMBLY

1. Rest locker section on flat surface and bolt center section to left and right 6 person lockers.
2. Stand locker upright.
3. Bolt coat rod bracket to one side of 6 person locker (End Section) below center section.
4. Insert coat rod into coat rod bracket. Place remaining rod bracket in open end of rod and maneuver rod and coat rod bracket to mounting hole on other 6 person locker and bolt into place.
5. Rivet number plate to doors.
6. Insert door pulls through slot in each door and bolt door pull to door.
7. Anchor locker to floor and wall.

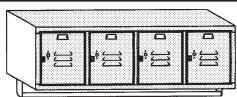
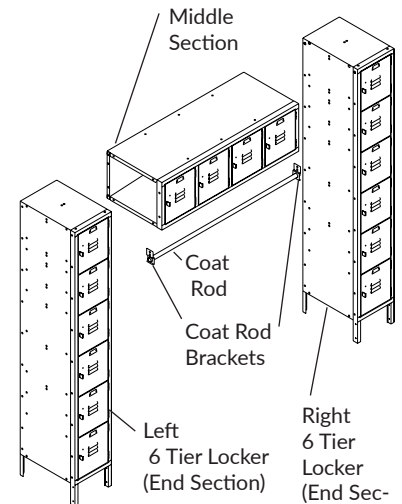

WALL MOUNTED LOCKER WITH COAT ROD

1. Use steps 1-3 from the Middle Section of the 16 Person Lockers Instructions above.
2. Bolt a 4 compartment locker end to each side of middle section.
3. Bolt the coat rod retaining plate to each side of 4 compartment locker end (end section). Bolt a 4 compartment coat hanging plate to one coat rod bracket.
4. Carefully inserts push-in thread washer 3/4" deep into each end of coat rod.
5. Insert coat rod into the attached coat rod bracket. Place remaining coat hanging plate in open end of coat rod and maneuver coat rod and coat rod hanging plate to mounting holes in the coat rod retaining plate and bolt into place.
6. Put 1/4-20 x 1-1/4" tuss head fin bolt into hole in coat rod retaining plate and coat hanging plate. Thread bolt in to push-in thread washer (in coat rod) and tighten bolts.
7. Insert door pulls through slot in each door and bolt door pull to door. Attach number plates to doors.
8. Anchor wall mounted locker to wall in 4 places with appropriate anchor bolt for wall. Place anchor bolt through hanging plate and then locker back (holes may need to be drilled) and bolt to wall.

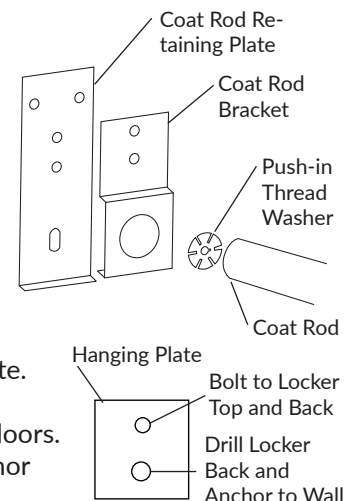

INVINCIBLE II LOCKERS

Invincible II Group End Kits

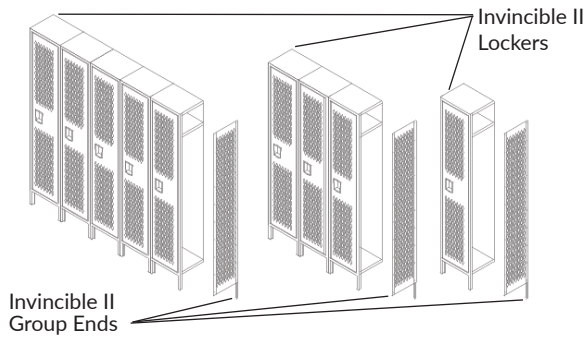

Invincible II lockers do not automatically come with group ends, they must be ordered separately. If you are short group ends, check with the person who ordered the lockers.

NOTE: solid divisions (group ends) are sometimes ordered to end rows of lockers that have perforated divisions everywhere else. Refer to drawings provided by the person who ordered the lockers for all layout details.

PENCO PRODUCTS, INC.

1820 Stonehenge Dr.,

Greenville, NC 27858

800-562-1000 • Fax 252-917-5294

www.pencoproducts.com