

Fasteners & Tools Needed

The following items are in the hardware kit shipped with the locker:

8615–Number plate



8671–Aluminum Rivet



8621- Steel rivet



8709-Screw



..

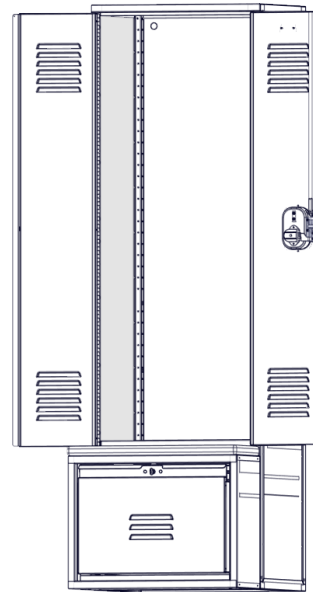

STEP 1- Check Parts

Unpack the component pieces for the basic locker. You should have two sides, a back, a top, and bottom, drawer assembly with front extension, left hand and right hand door.

You will need these tools to assemble the Patriot Duty locker.

Rivet gun.

Drill with #3 Philips bit



Flat blade and Phillips head screwdrivers.

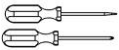

Stepladder

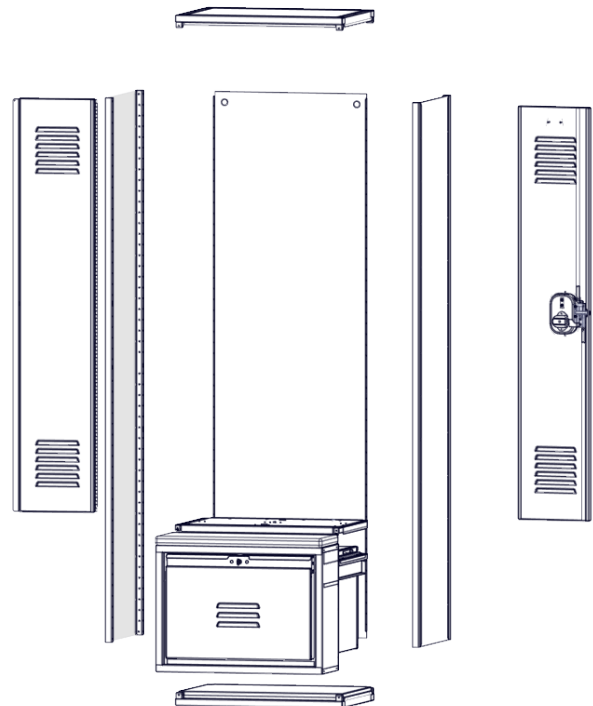

Note- Assemble locker upside down to allow screw insertion into underside of locker bottom. Images shown may differ from your locker, as there are different configuration options. Some parts show with transparency in these instructions to add clarity to assembly.

STEP 2 – Assemble the locker body

2A- Lay locker top on flat surface on the ground. Insert the two sides onto the cast corner pieces of the top assembly.

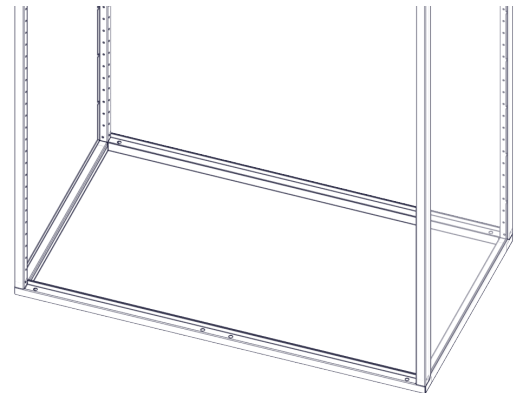
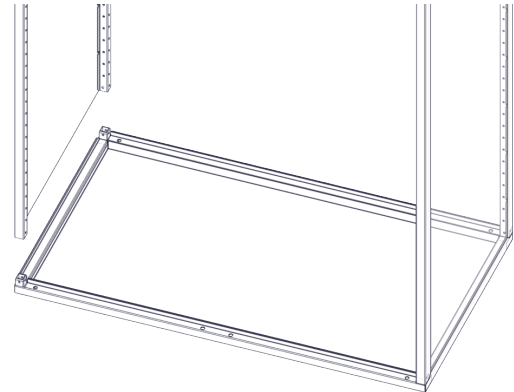
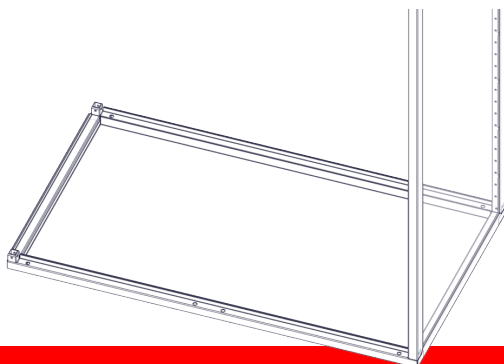
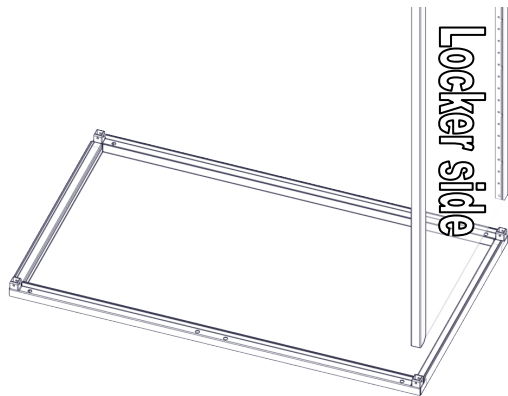
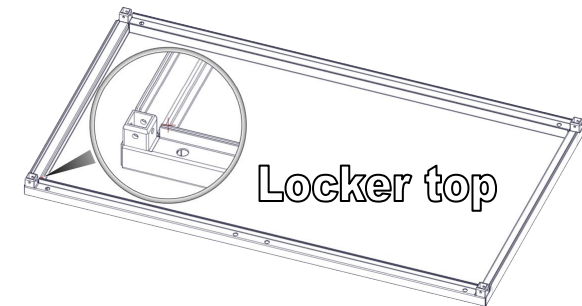

2B-1 Insert locker back into slot of the top.

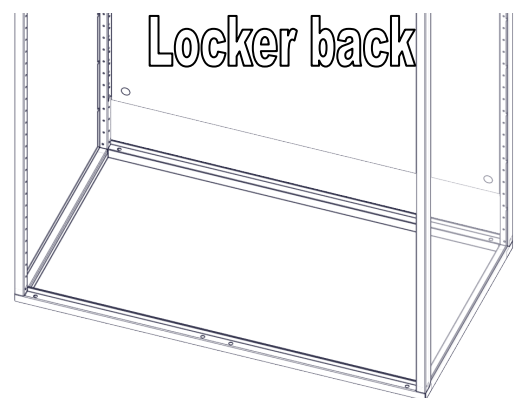

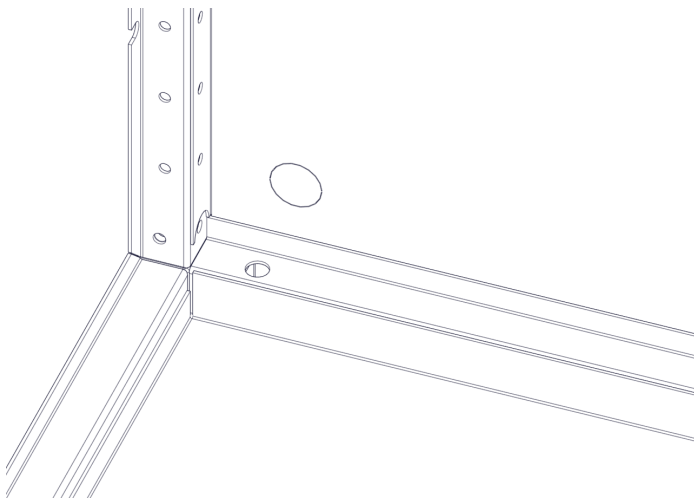
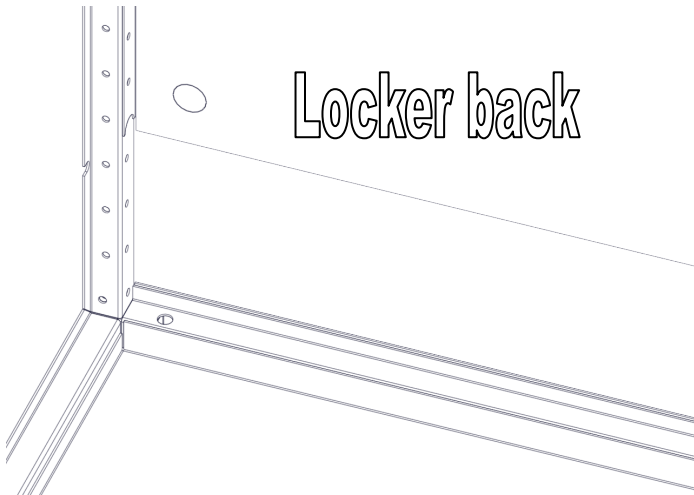

2B-2 With the back inserted install one 8709 screw on each side of the back about half way up. Note holes are to align to make sure back is in proper position.

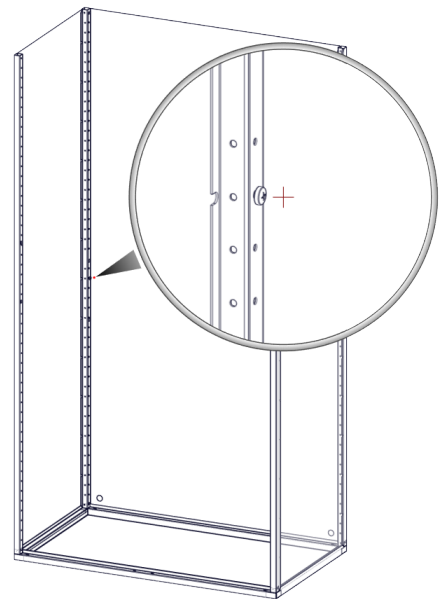
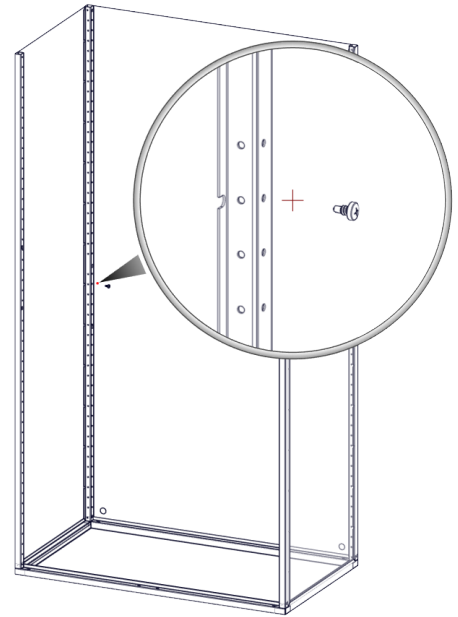

Fully Framed Duty Locker – KD Assembly Instructions

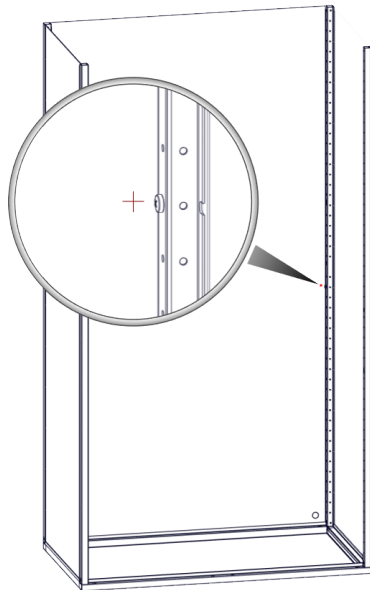
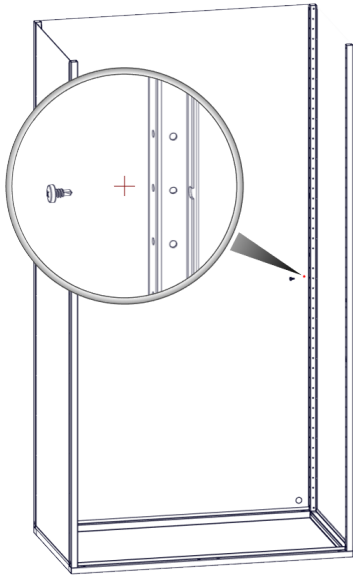

2C-1 Insert cast corner pieces of locker bottom into the side channels.

Locker bottom

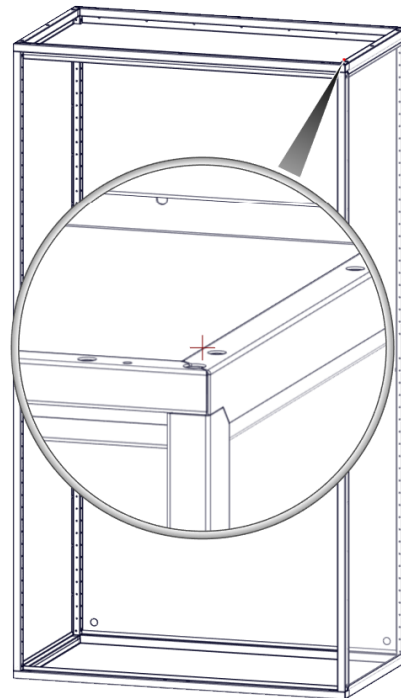
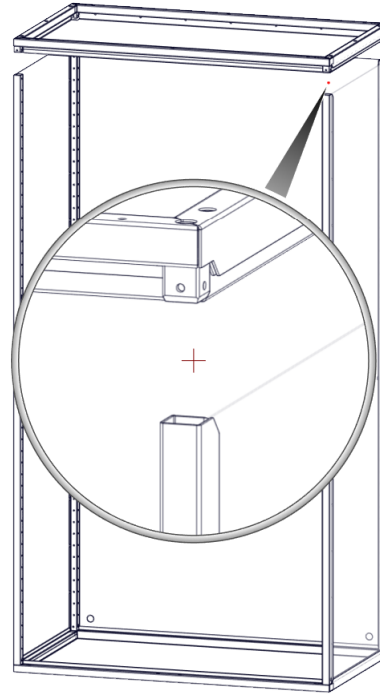

Fully Framed Duty Locker – KD Assembly Instructions



2C-2 Install one screw into each corner of the locker bottom as shown.

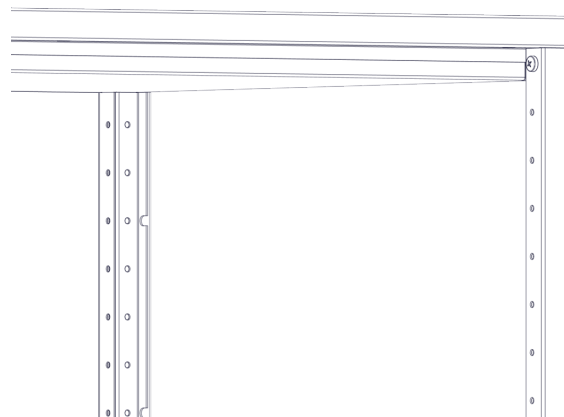
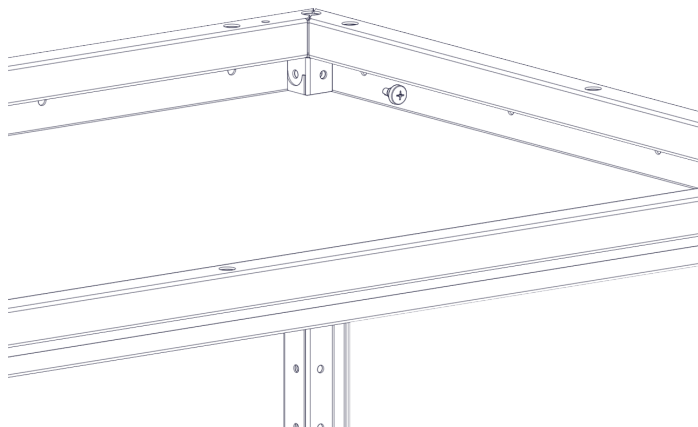
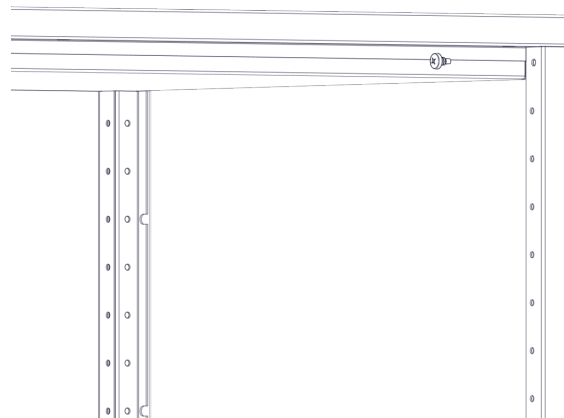
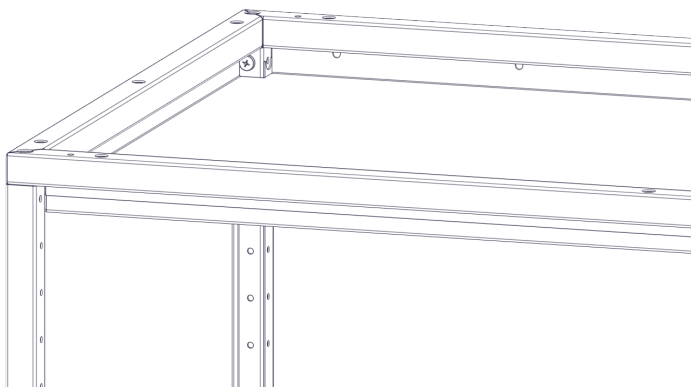
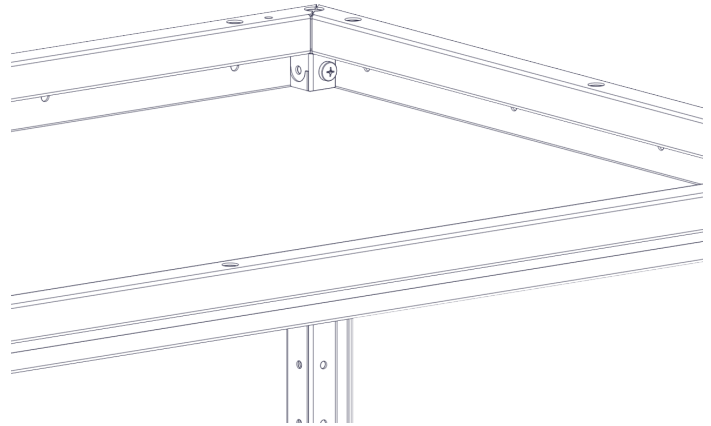
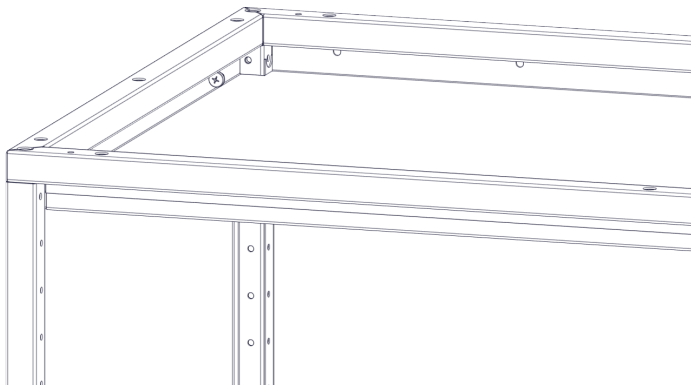

Fully Framed Duty Locker – KD Assembly Instructions

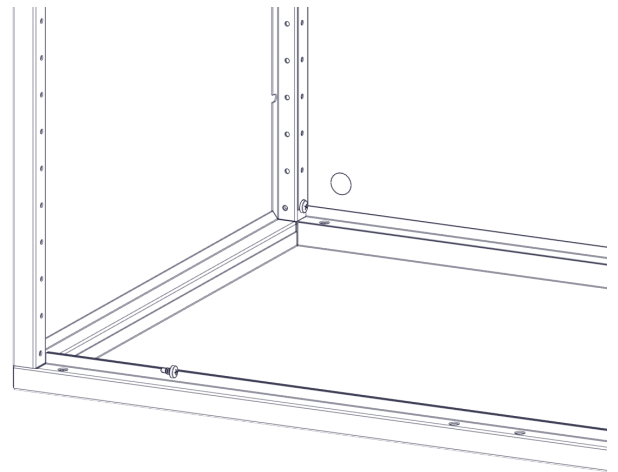
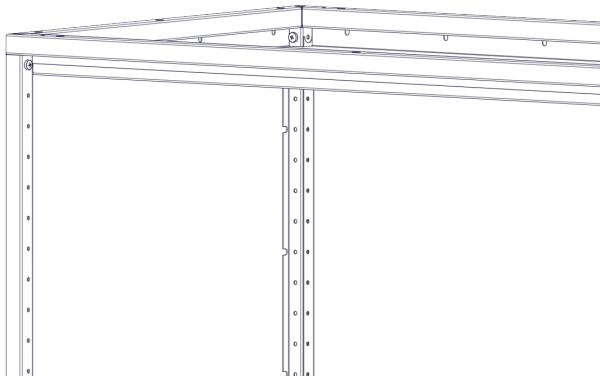
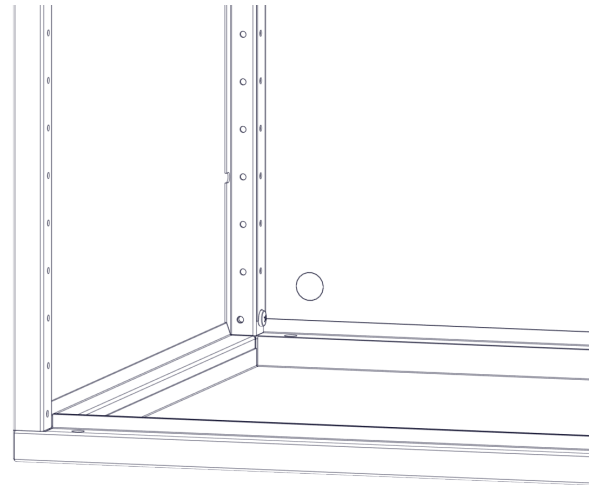
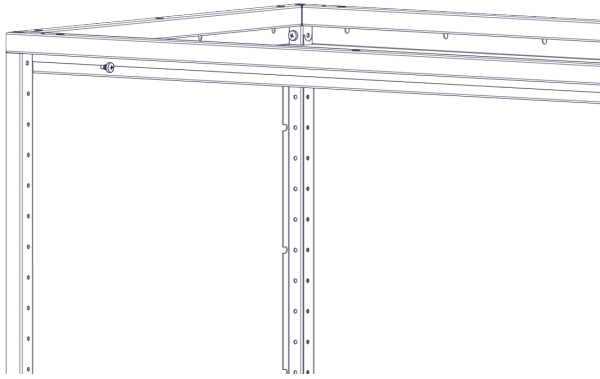

2D- Next install one screw into the locker top in each corner as shown.

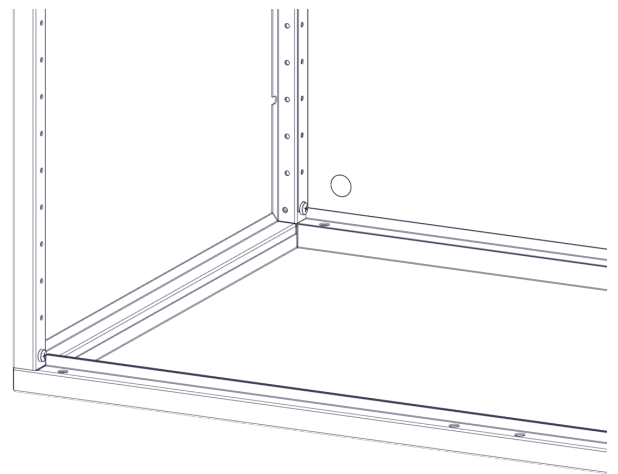
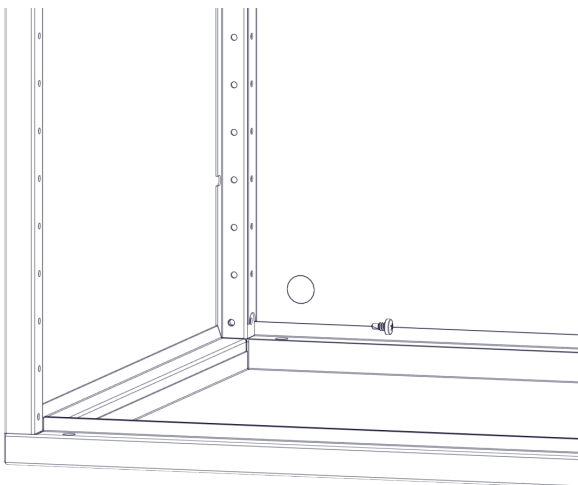

Fully Framed Duty Locker – KD Assembly Instructions

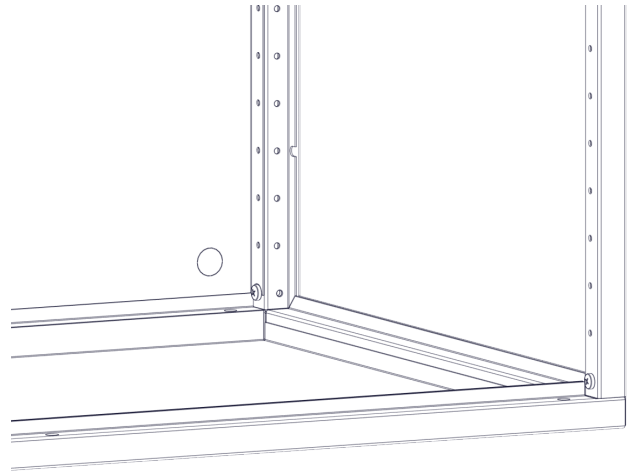
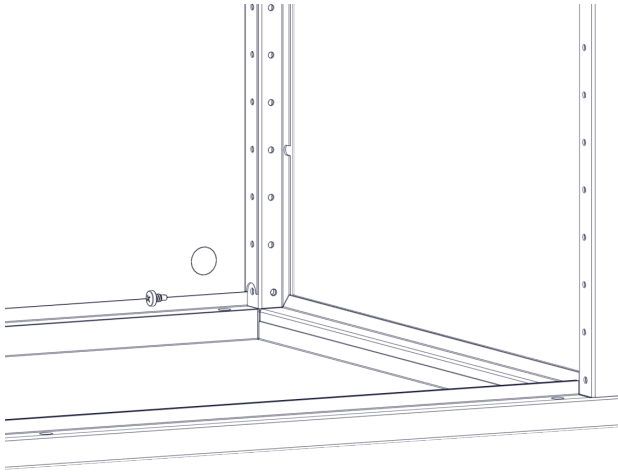

2E- Now rotate locker body so the bottom is on the ground.

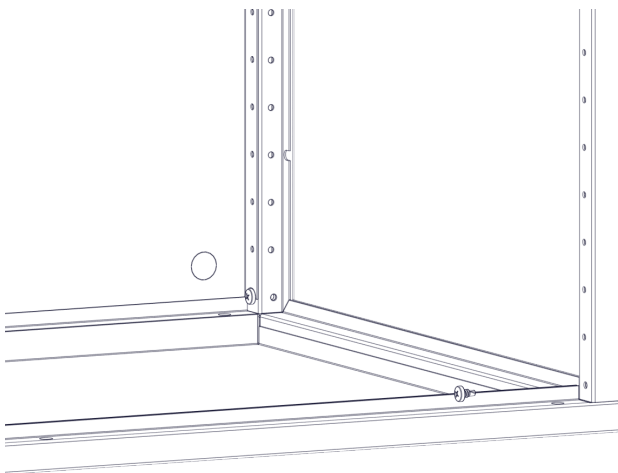
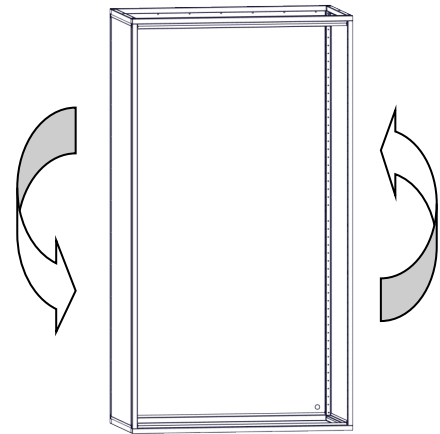
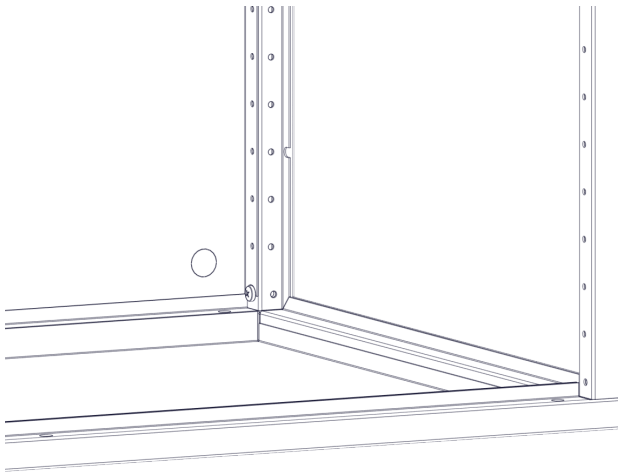

Fully Framed Duty Locker – KD Assembly Instructions

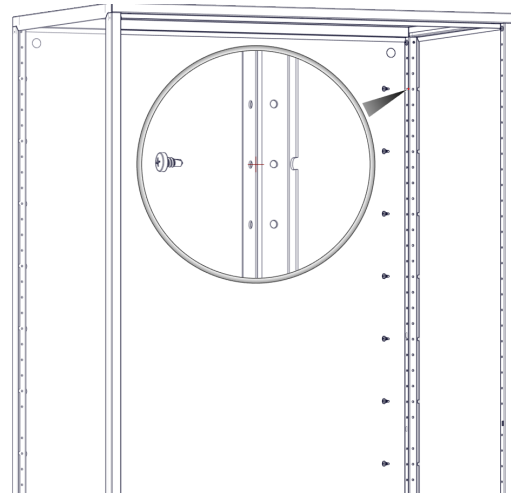
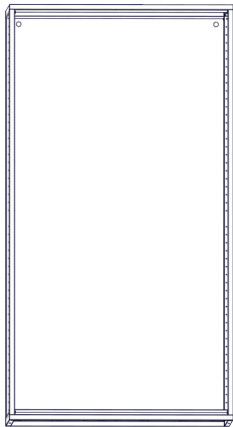
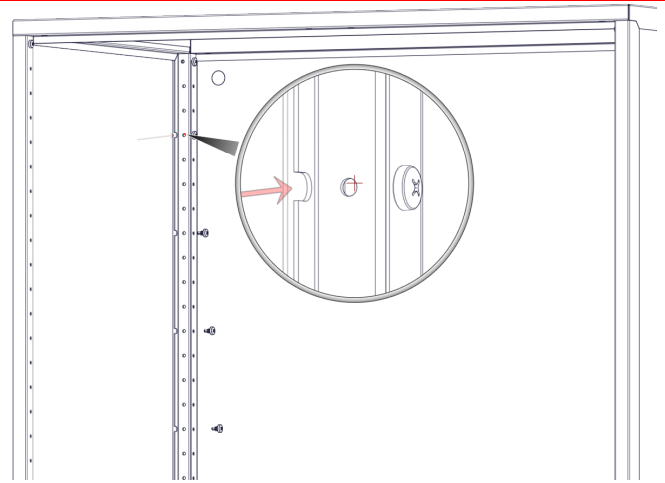
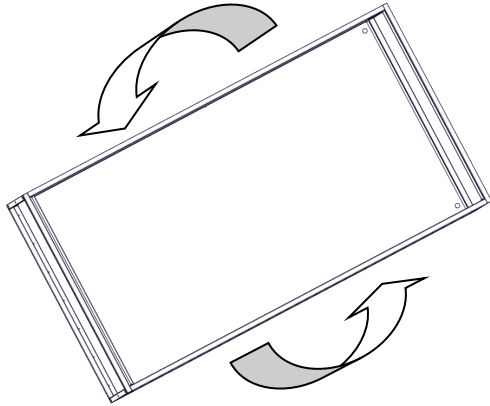

2F-Install screws to locker back at U cut locations (6-inch intervals) on each side.

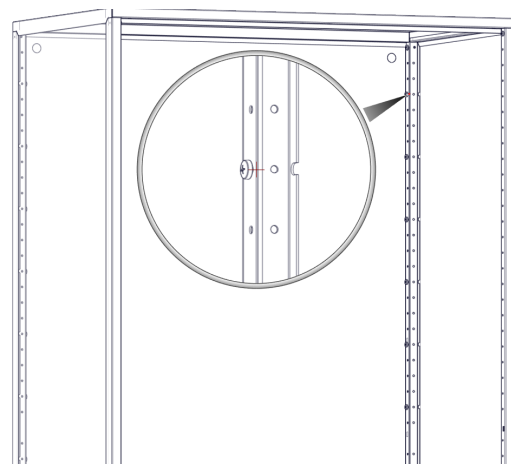
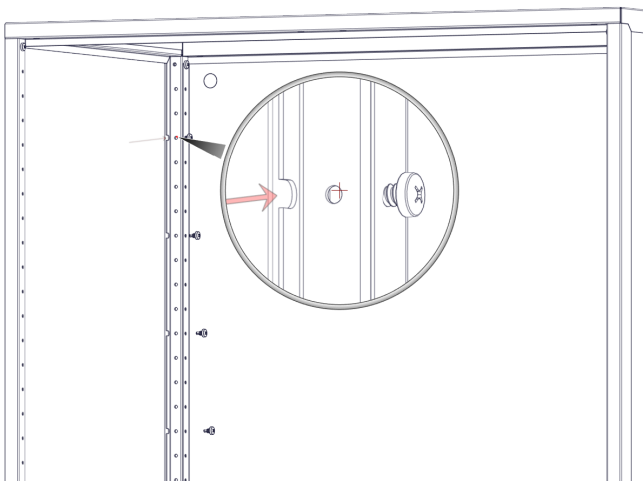

Fully Framed Duty Locker – KD Assembly Instructions



2G-Install doors using 8621 rivets at each hole location on hinge.

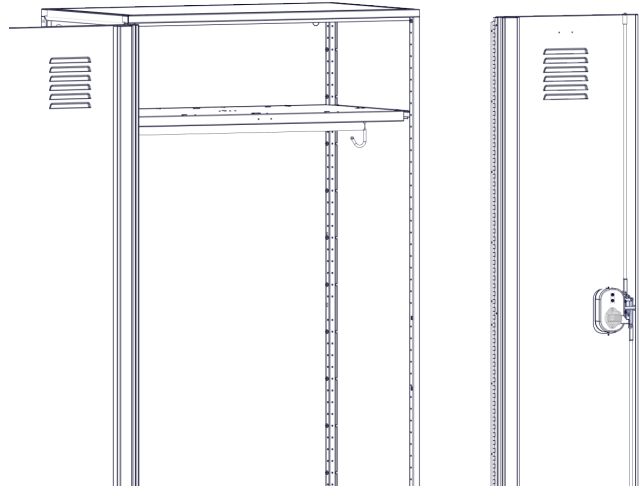
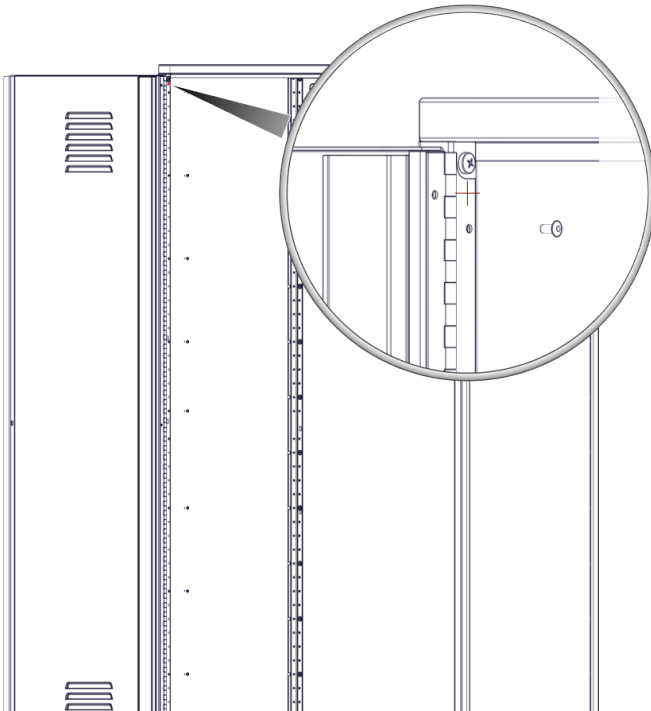
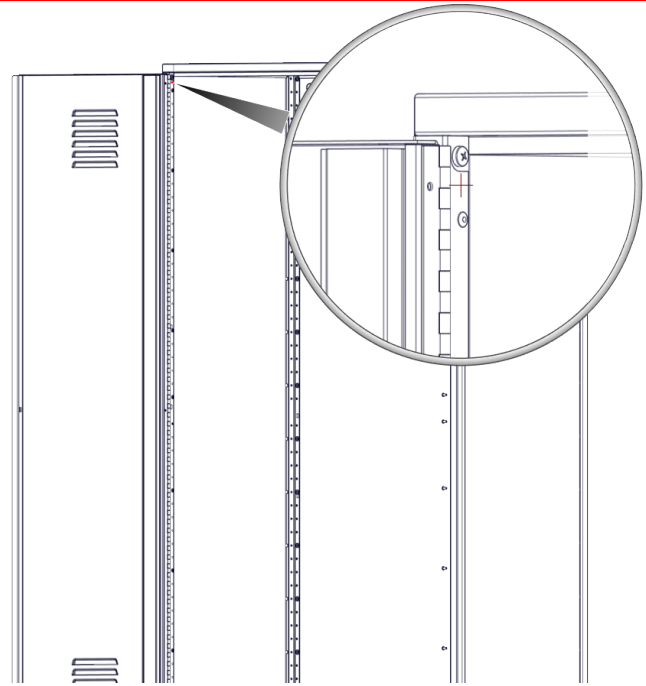
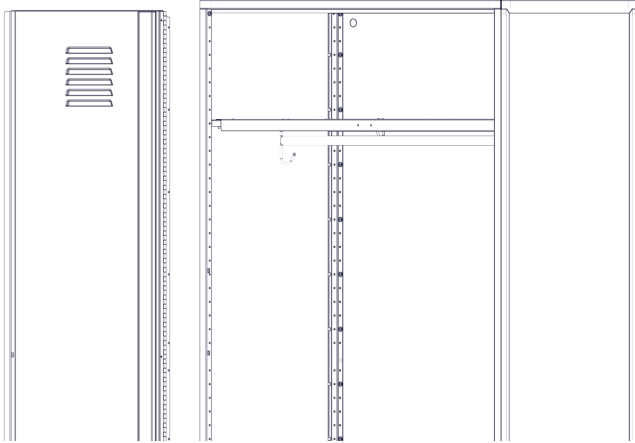

Fully Framed Duty Locker – KD Assembly Instructions



2H-Install support rails for shelf/bottom and install shelf/bottom.

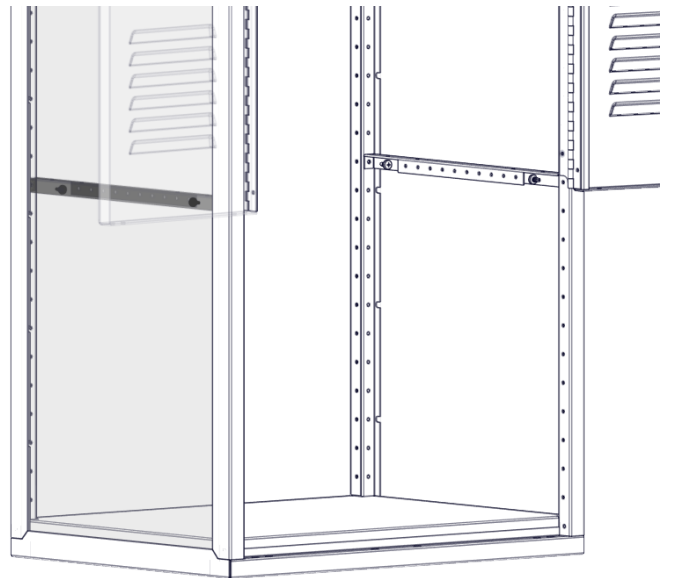
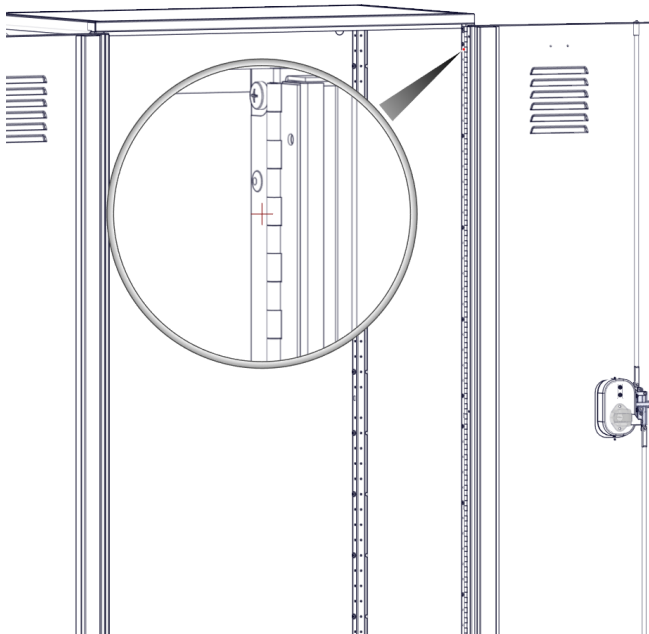
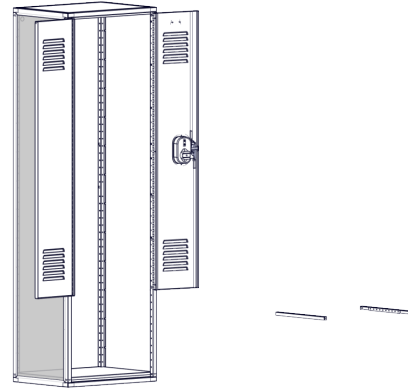
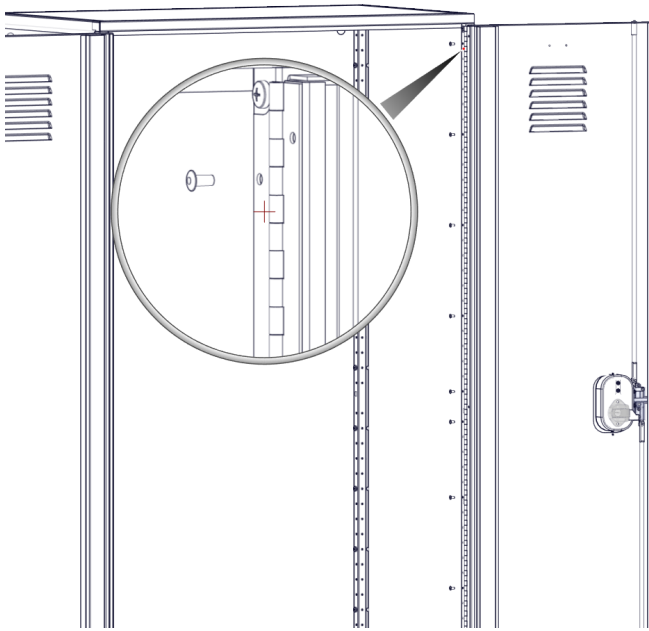

Fully Framed Duty Locker – KD Assembly Instructions

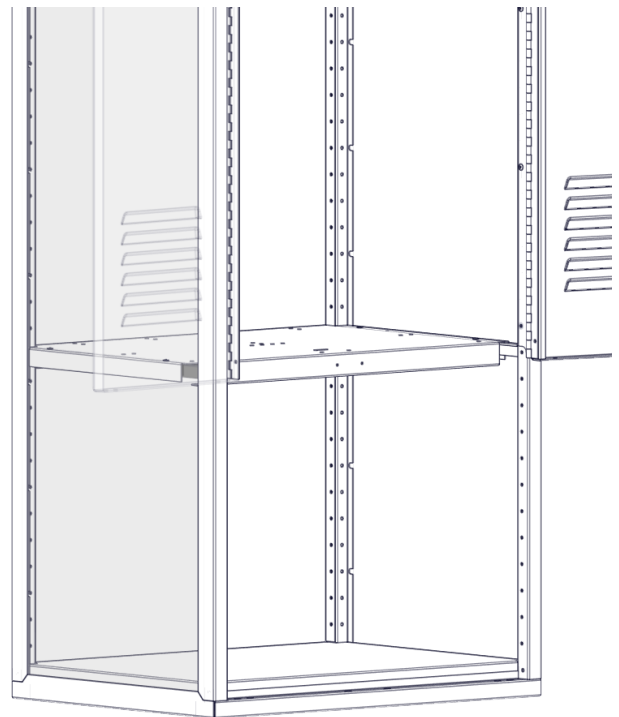
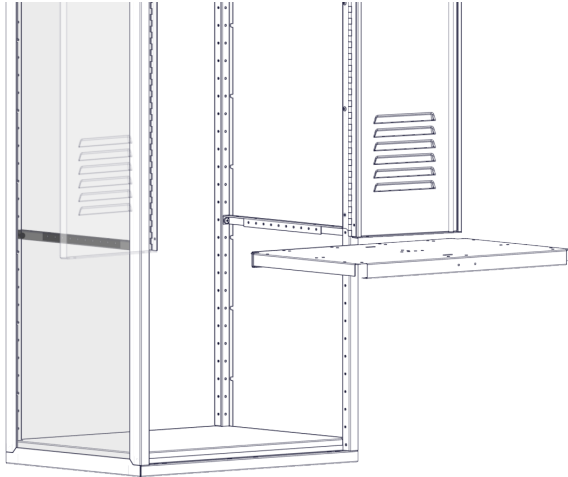
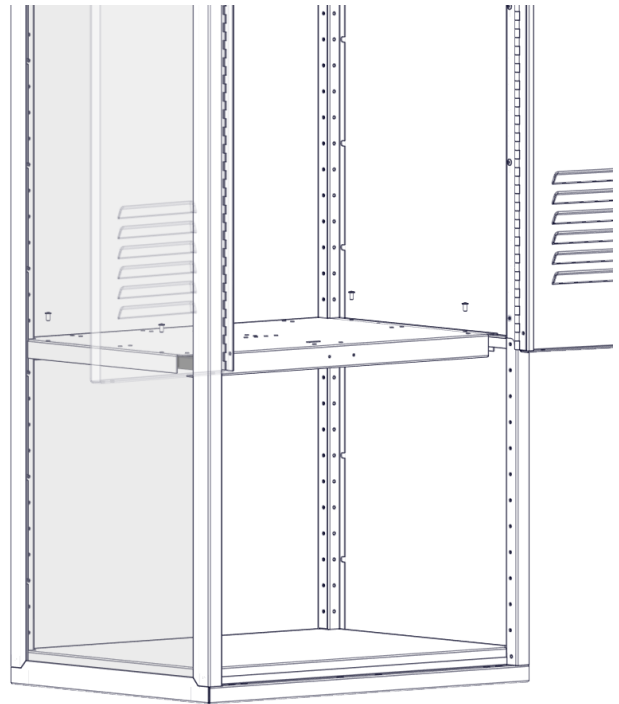
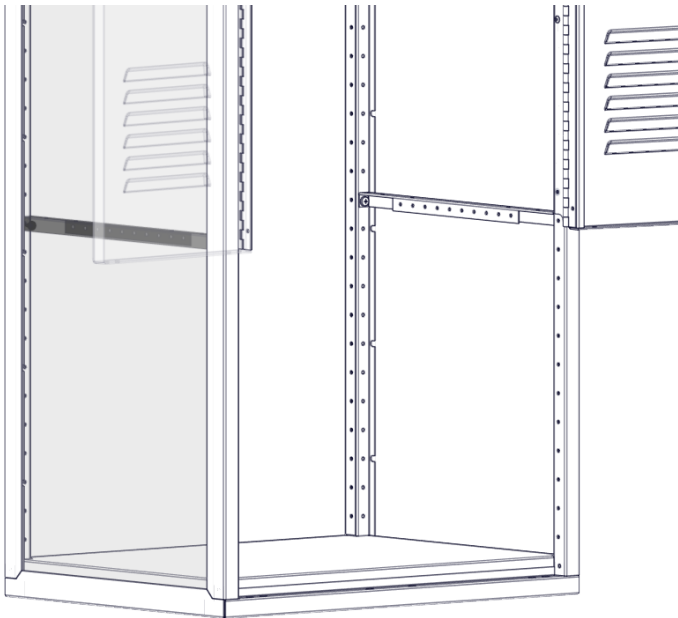

Fully Framed Duty Locker – KD Assembly Instructions



2I-Install support rails for drawer guides and install drawer guides.

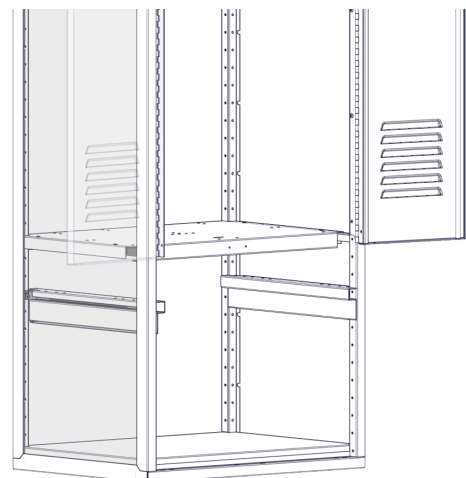
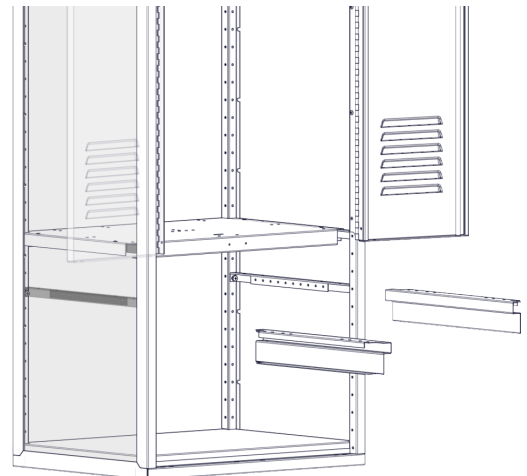
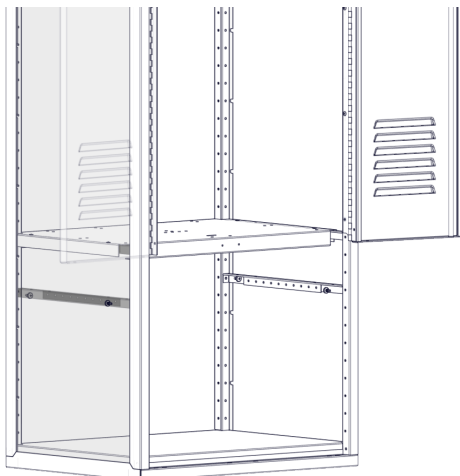
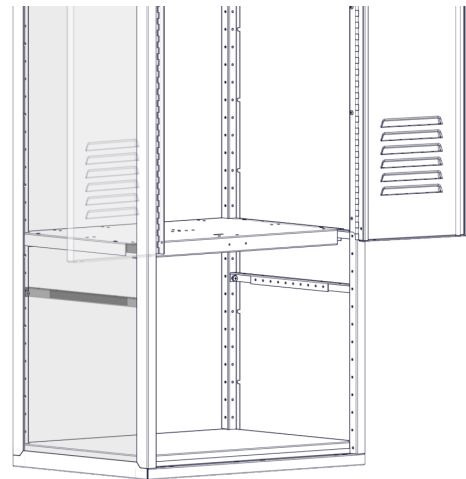
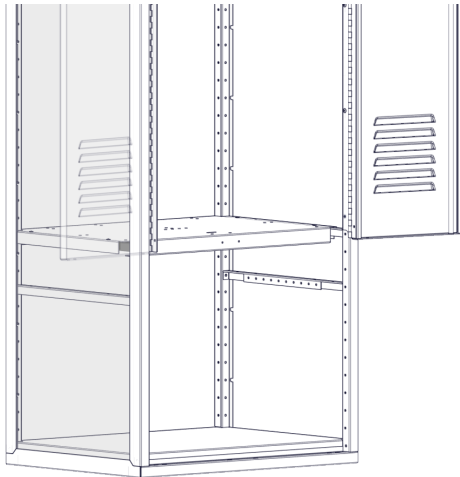

Fully Framed Duty Locker – KD Assembly Instructions

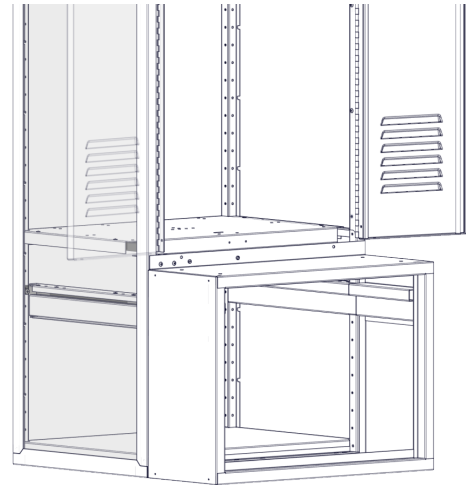
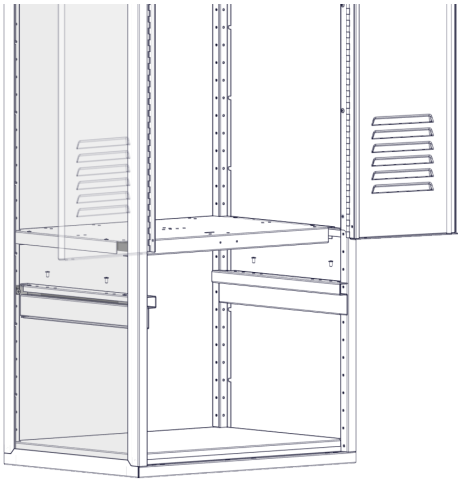

Properly align drawer front extension and add self-tapping screws.

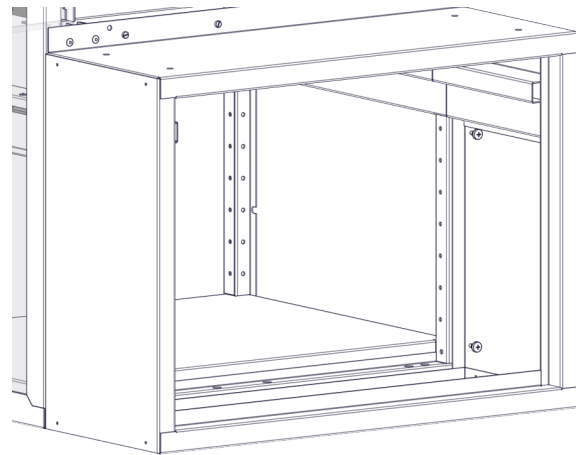
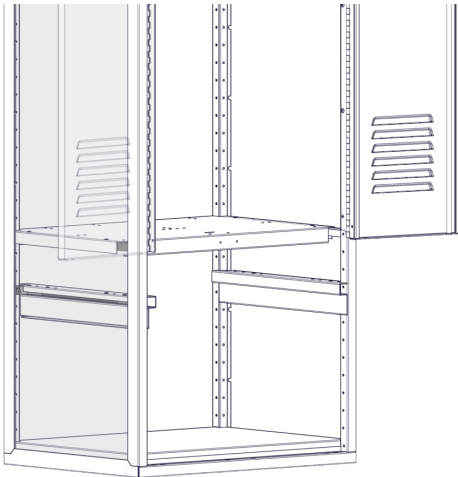

2J-Install drawer front extension.

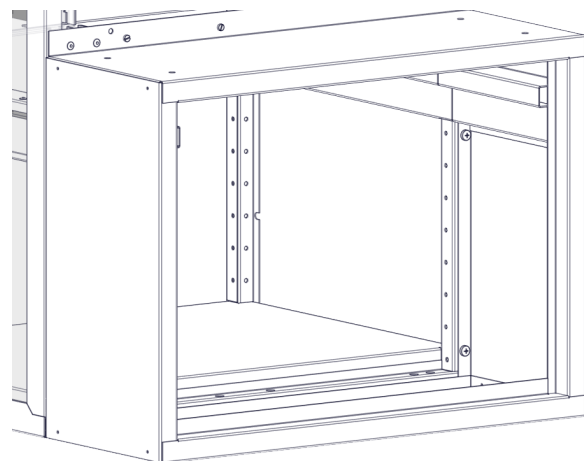
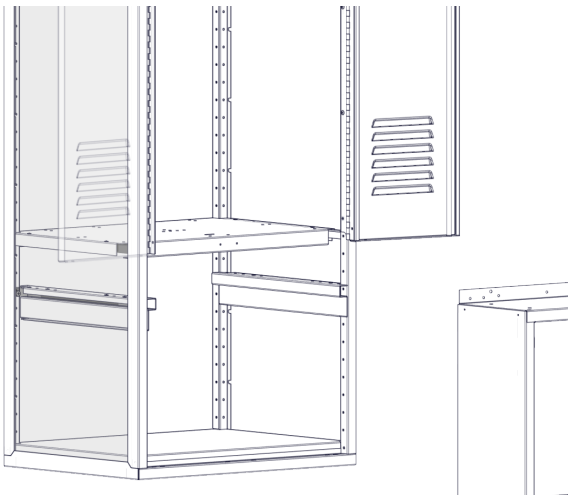

Fully Framed Duty Locker – KD Assembly Instructions



2K-Install gap filler cover and add two rivets as shown.

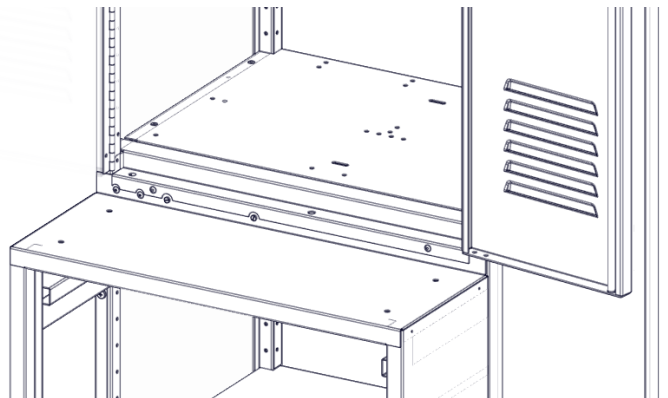
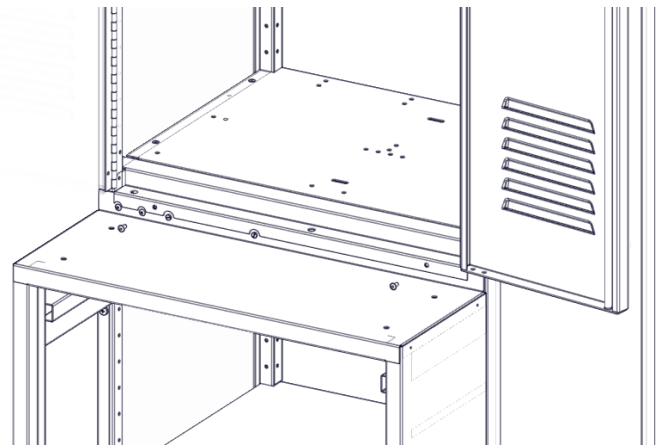
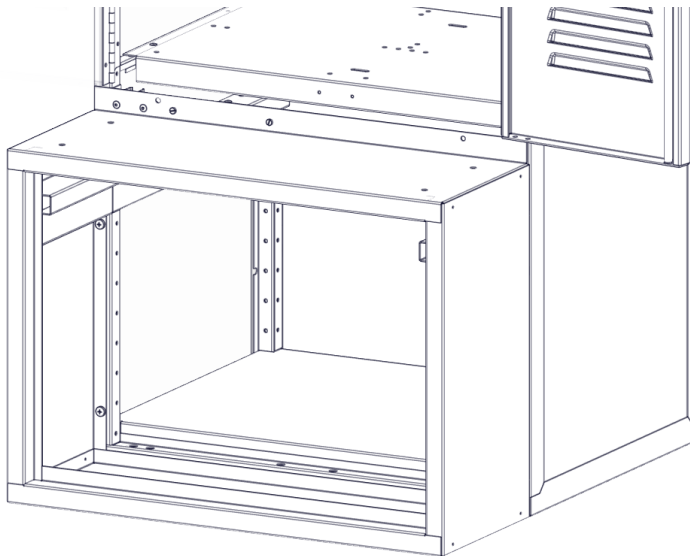
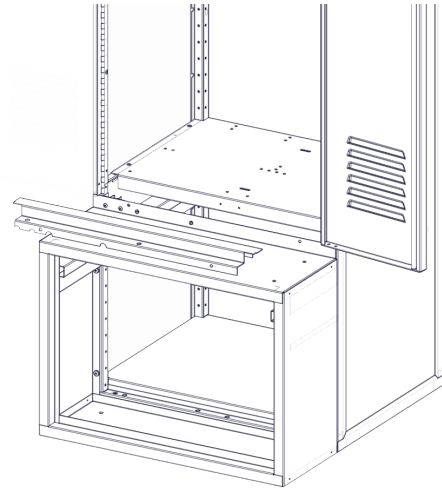
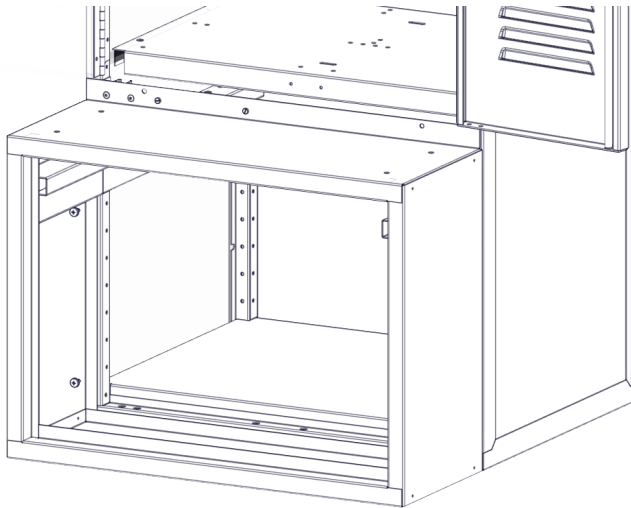

Fully Framed Duty Locker – KD Assembly Instructions



2L-Install plastic drawer glide covers using two screws on each glide as shown.

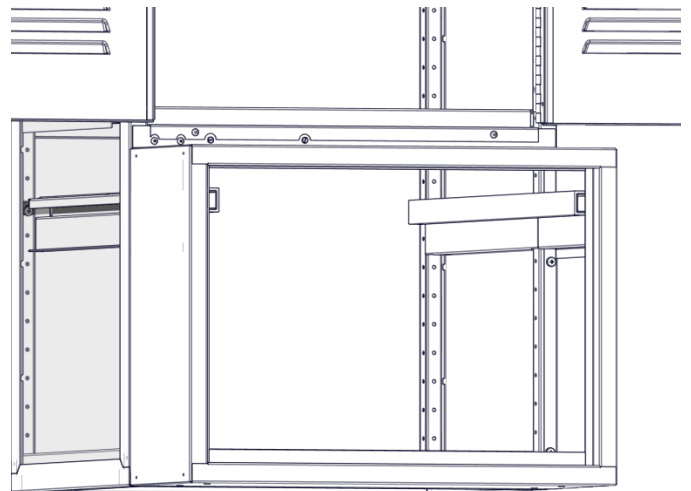
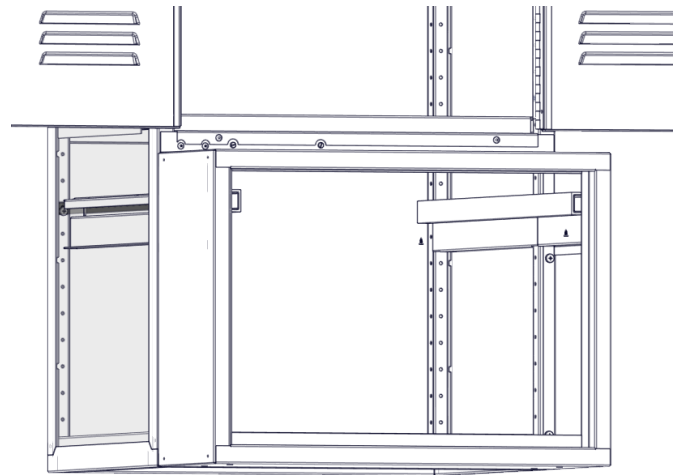
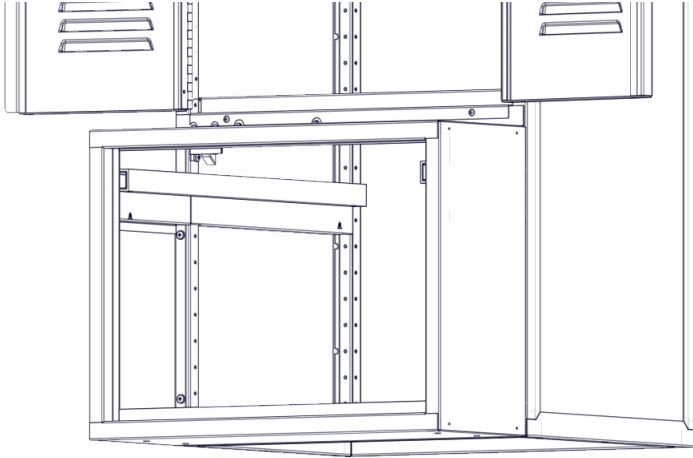
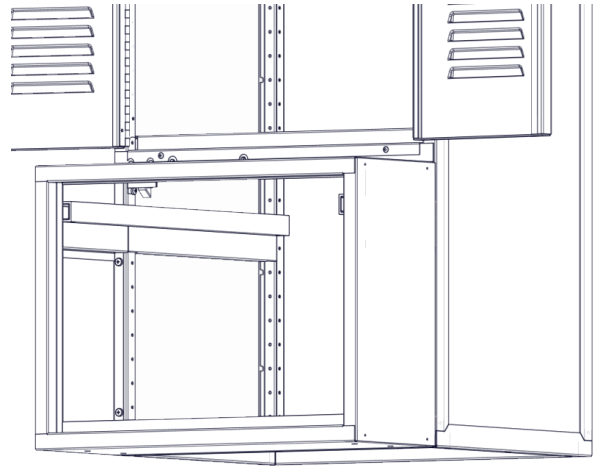
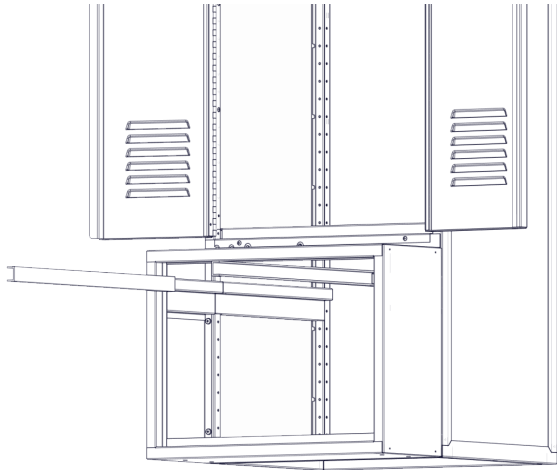

Fully Framed Duty Locker – KD Assembly Instructions



2M-Install bench using four lag screws as shown.

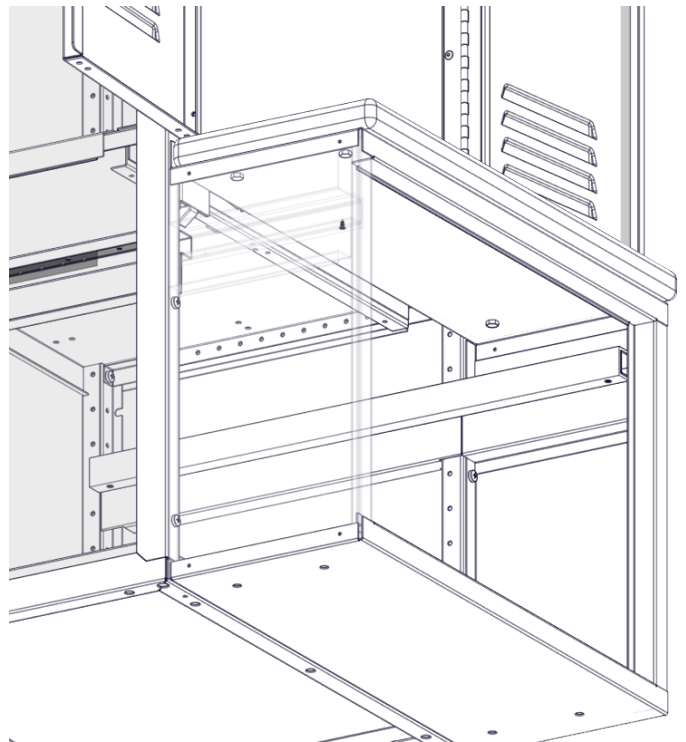
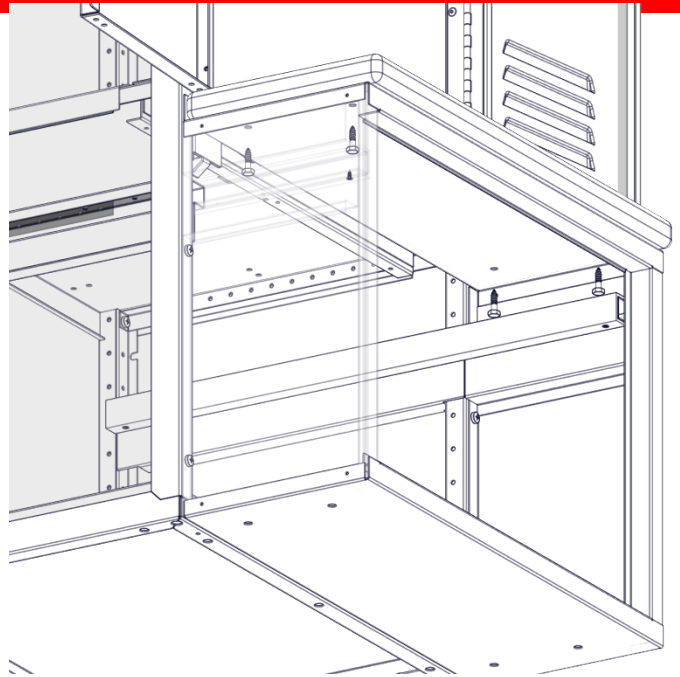
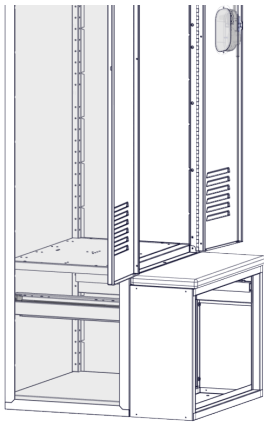
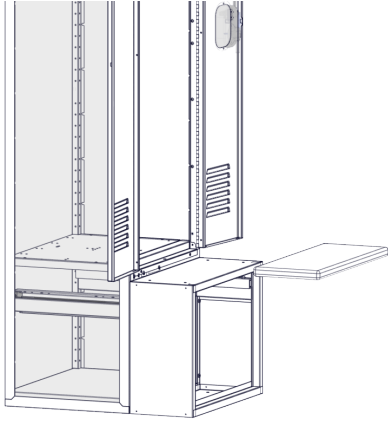

Fully Framed Duty Locker – KD Assembly Instructions

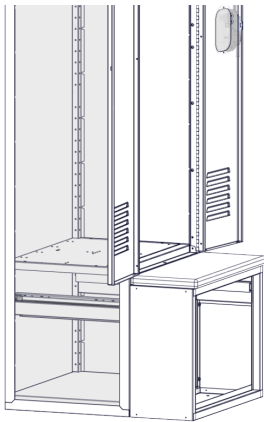

2N-Install drawer onto drawer glides.

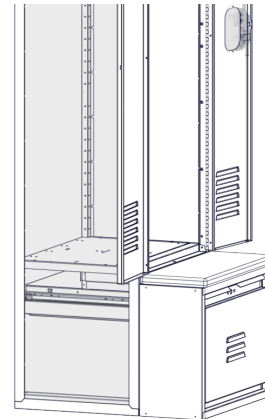

Shell assembly is now complete. You can now add locker accessories. Lockers to be floor and wall anchored before use.

