

Fasteners & Tools Needed

8621- Steel rivet 

8709-Screw 

You will need these tools to assemble the accessories into locker.

Rivet gun.

Drill with #3 Philips bit



Flat blade and Phillips head screwdrivers.

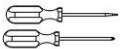

Table of Contents

Step 1.....Security Box Installation
 Step 2.....L Shelf Installation
 Step 3.....Inner Compartment Installation
 Step 4.....Center Partition Installation
 Step 5.....Half Shelf Installation
 Step 6.....6” Drawer Installation
 Step 7.....12” Side by Side Drawer Installation
 Step 8.....Footlocker Installation
 Step 9.....Metal and Wooden Seat Installation
 Step 10.....Channel Base Installation
 Step 11.....Document Sleeve Installation
 Step 12.....Cell Tray Installation
 Step 13Coat Rod Installation

STEP 1 – Assemble and install optional security box.

Note security boxes can go on right or left side of locker shelf. Attachment of divider is opposite of security box placement.

Parts:

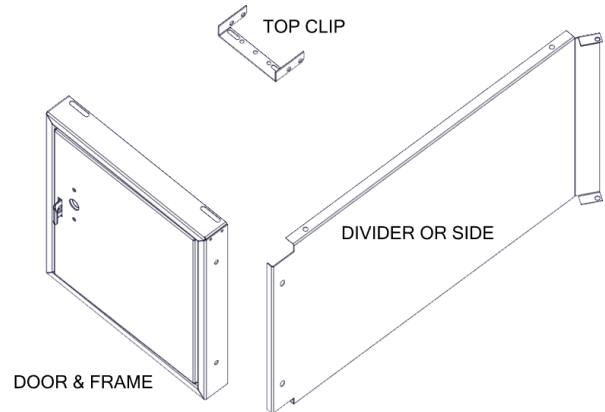

Step-1A Security box assembly and Installation
 Assemble the security box side to the frame using two rivets as shown. Note if locker sides are perforated and you need to hide security box contents then an additional side is required. Install this extra side on the opposite side facing the same way as the one in the image below.

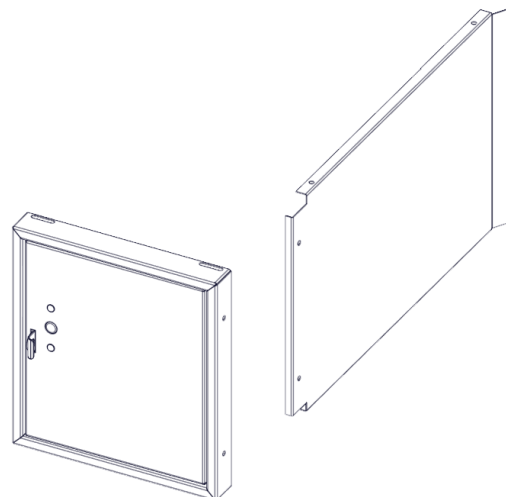

Fully Framed Accessory Assembly Instructions

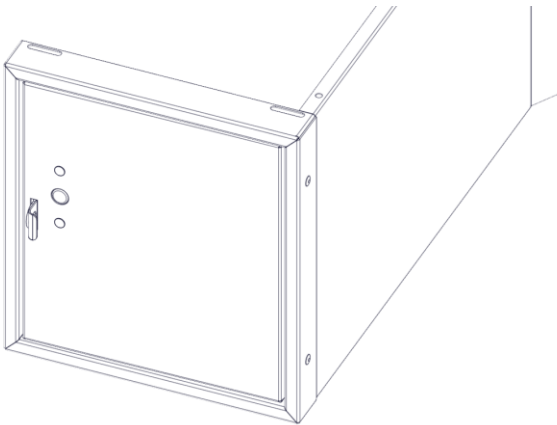
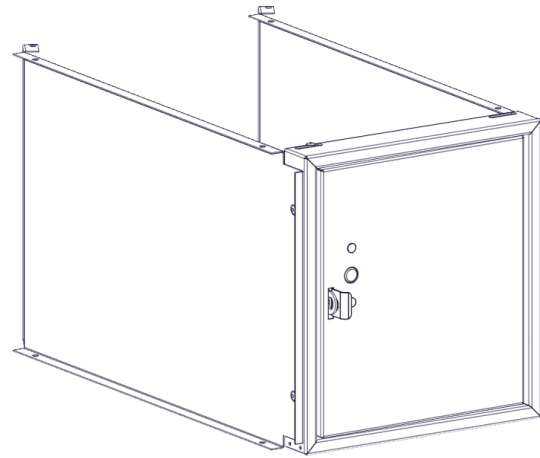
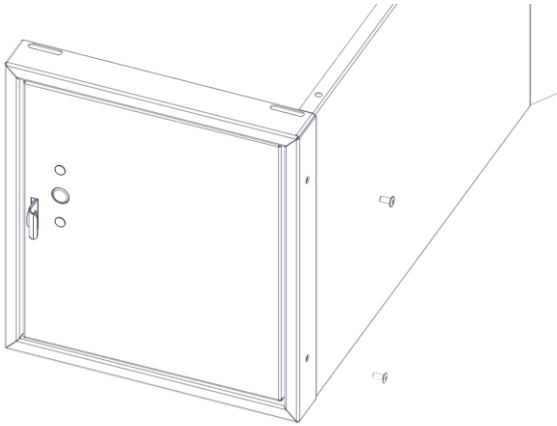

1B Install security box by sliding it onto the shelf in the appropriate position and secure it using four rivets as shown.

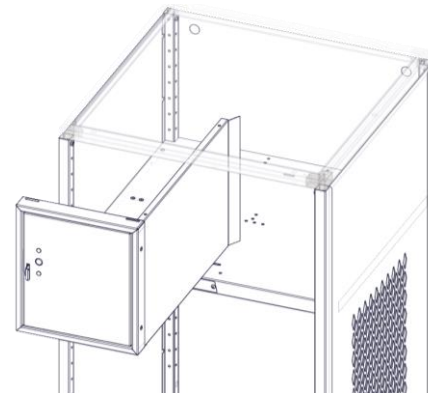

Optional side cover for hiding security box contents when locker sides are perforated.

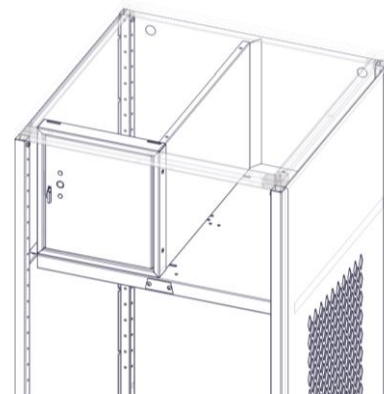
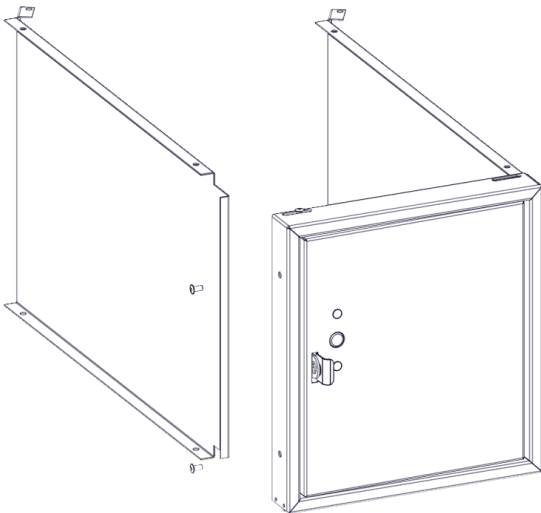

Fully Framed Accessory Assembly Instructions

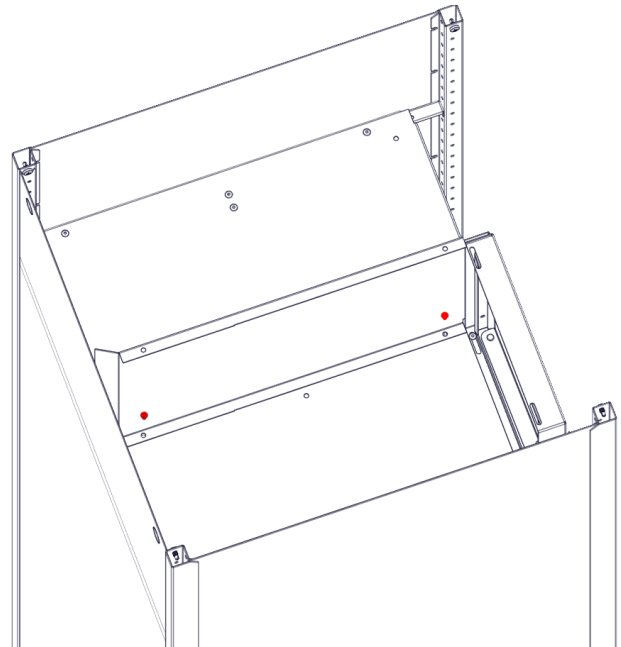
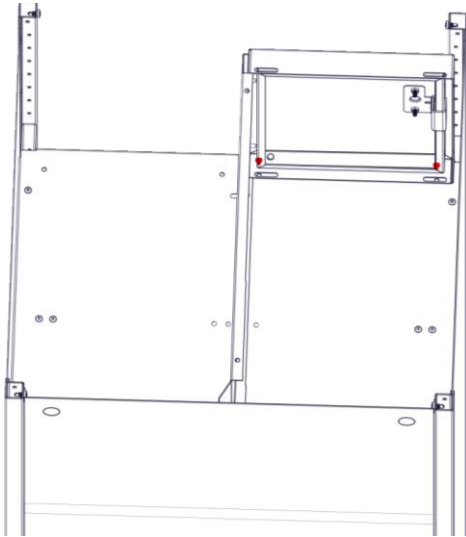
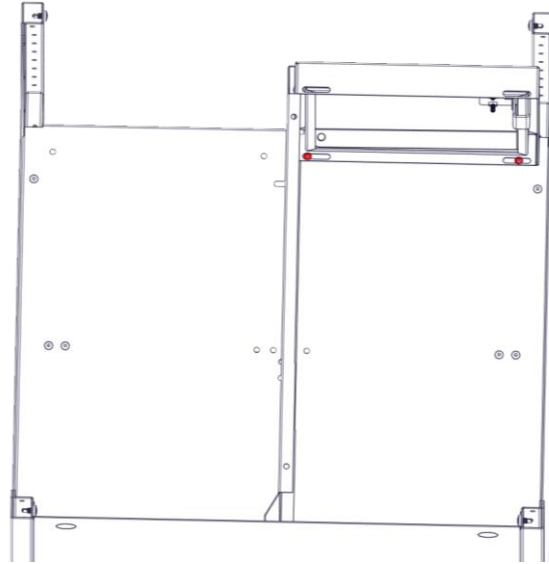
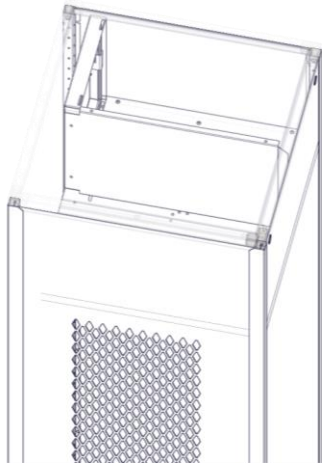

Fully Framed Accessory Assembly Instructions

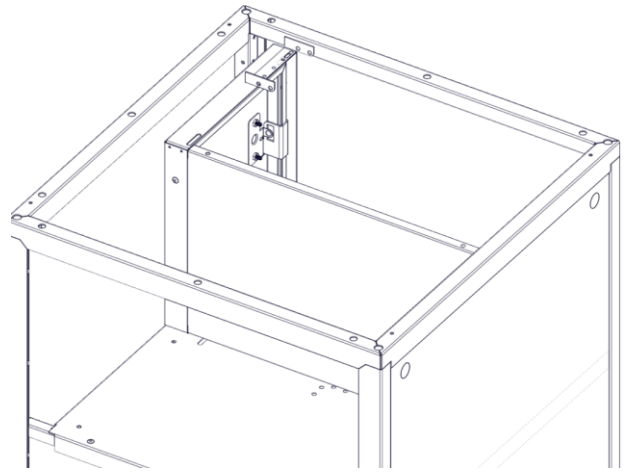
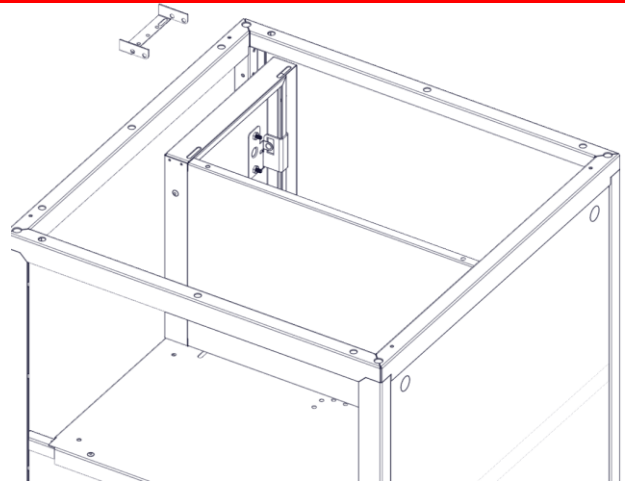
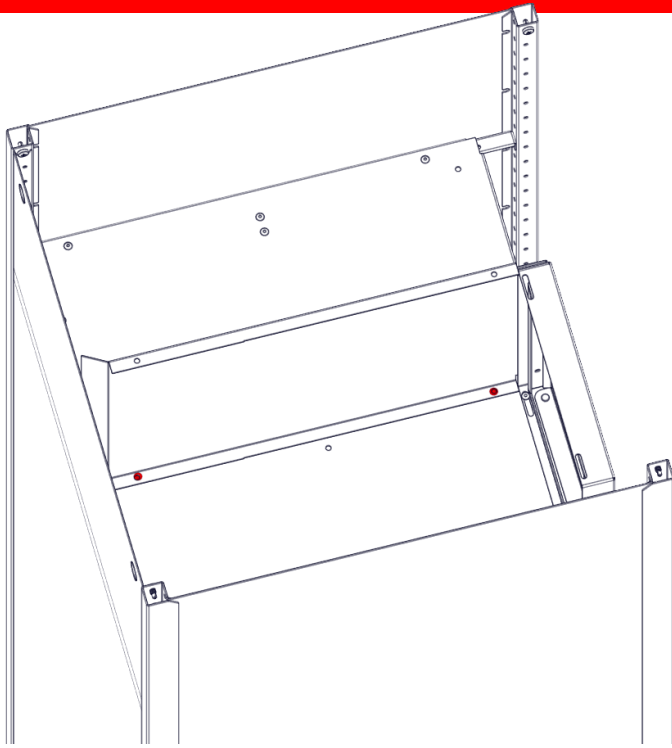

1C Install top clip to locker top rail and to doorframe using screw and rivets as shown.

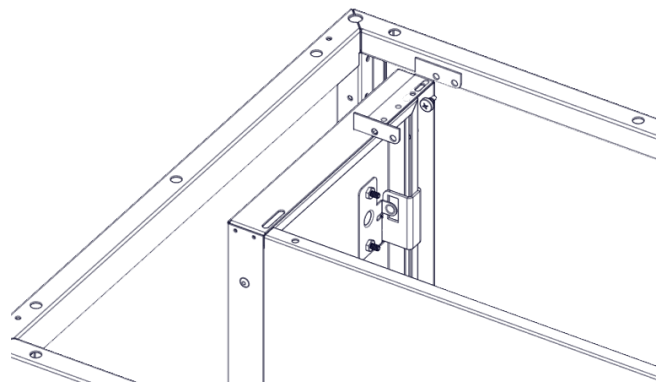
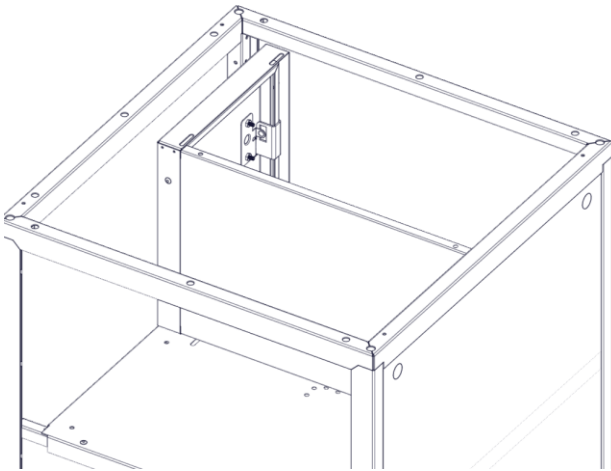

Fully Framed Accessory Assembly Instructions

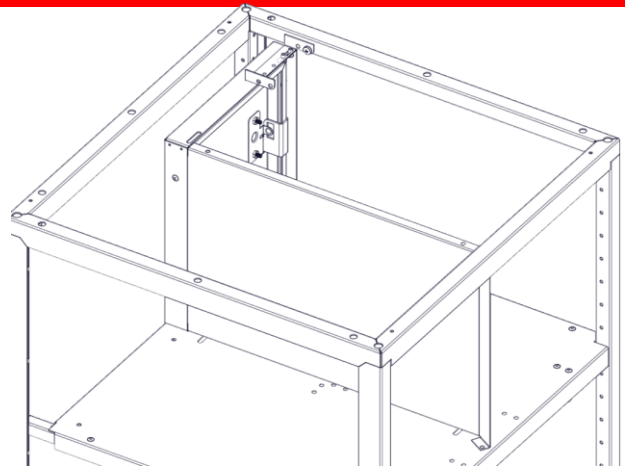
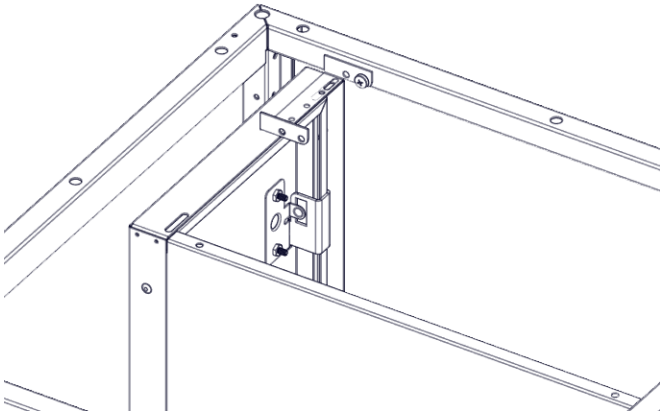

1D Install screw through security box division and into the locker top back rail as shown. Note locker back is invisible to show clear view.

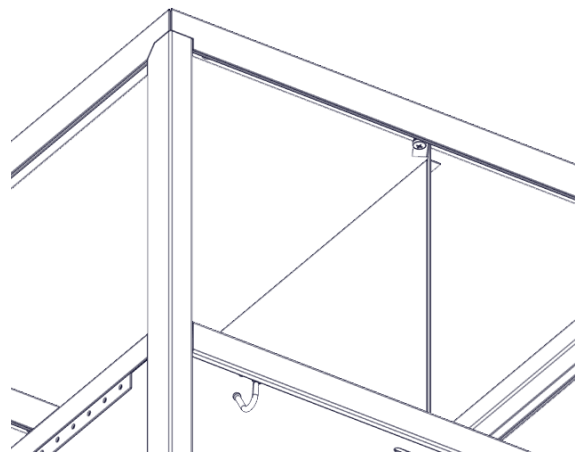
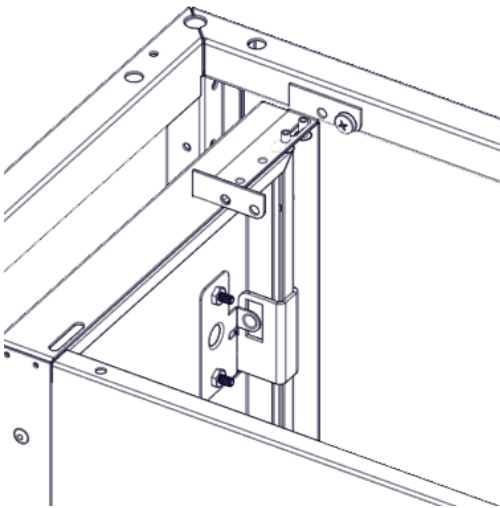
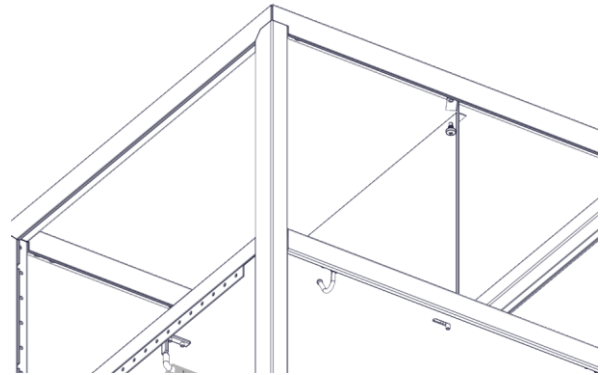
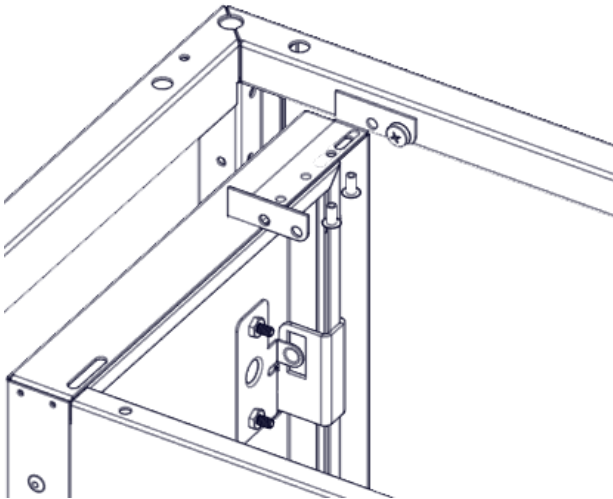

Fully Framed Accessory Assembly Instructions

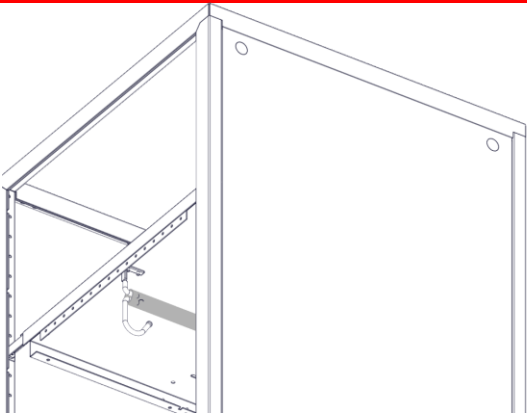

If optional side cover is needed install as shown below.

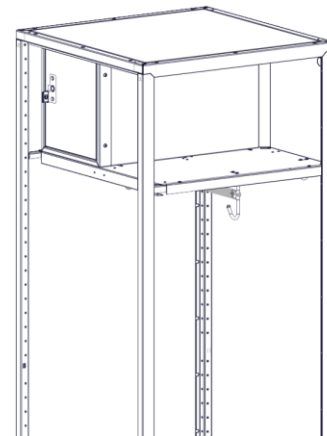
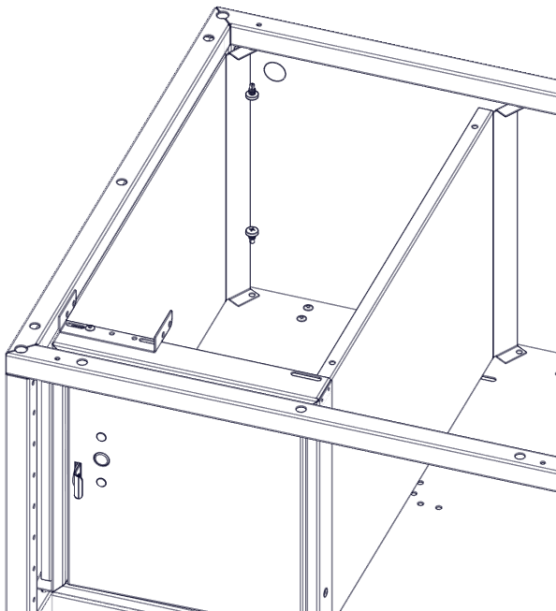
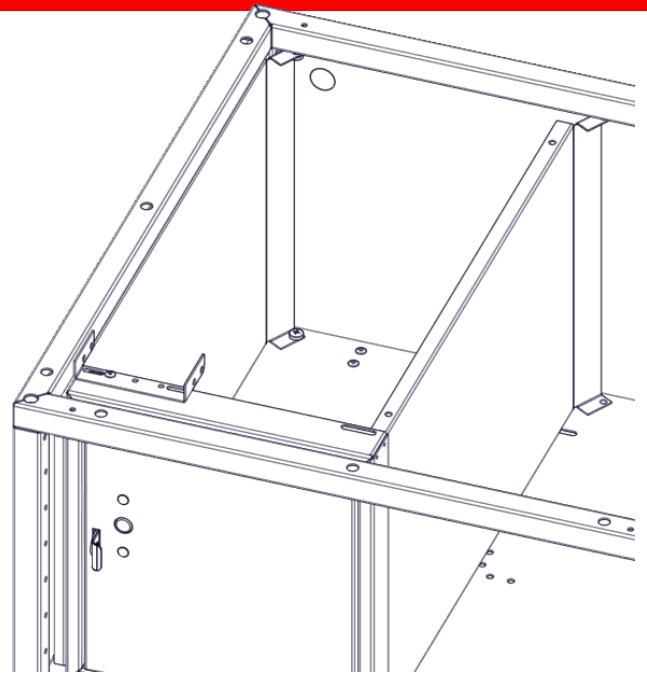

Installing an L shelf.

Step-2A install L shelf support rail at the proper height (12 inches down from shelf) using one screw into each vertical upright. 2B Place L shelf on top of support rail and locate on shelf above and insert four rivets to hold in proper location.

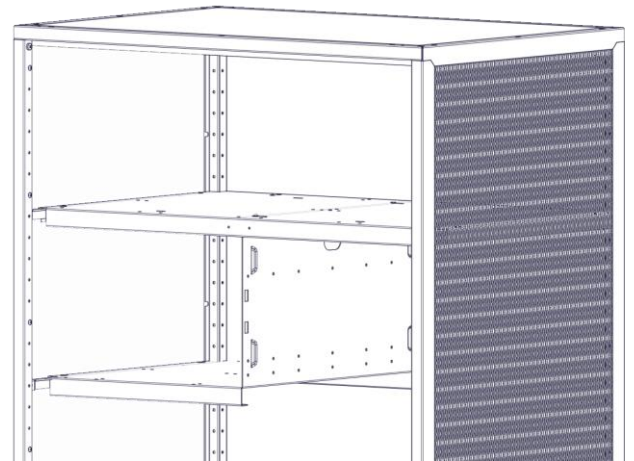
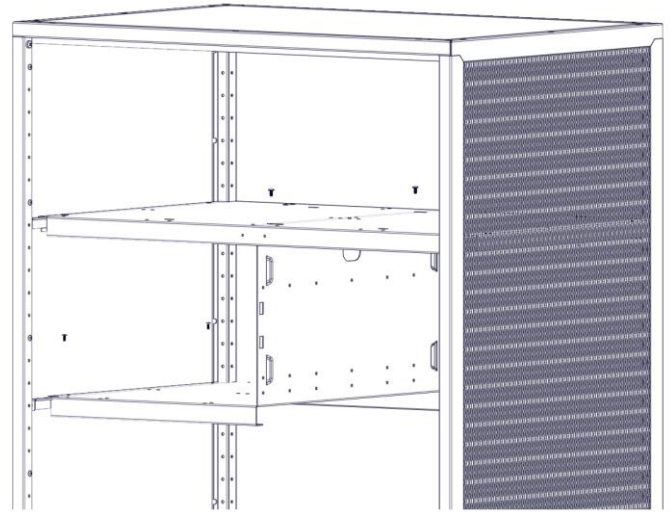
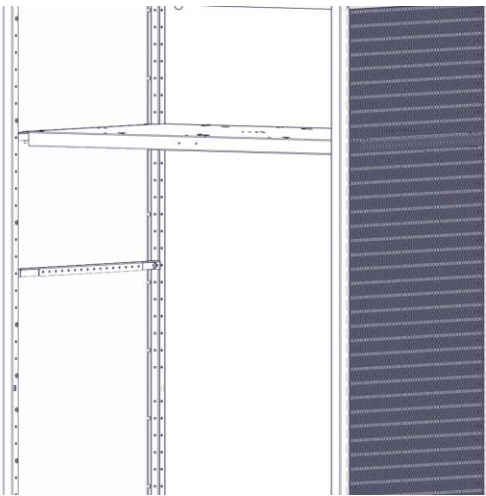
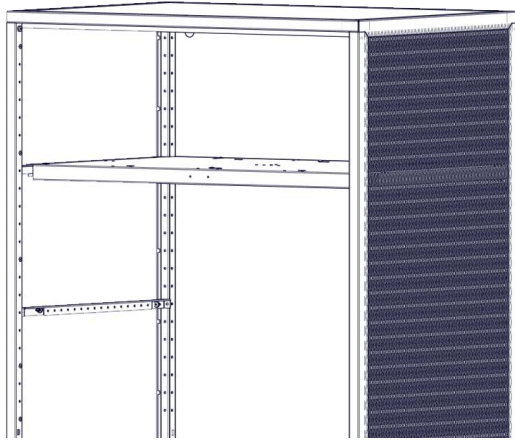

Fully Framed Accessory Assembly Instructions



Repeat this process again for additional shelves.

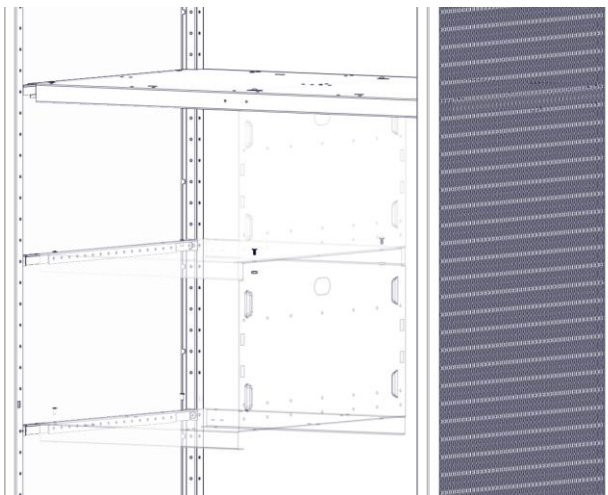
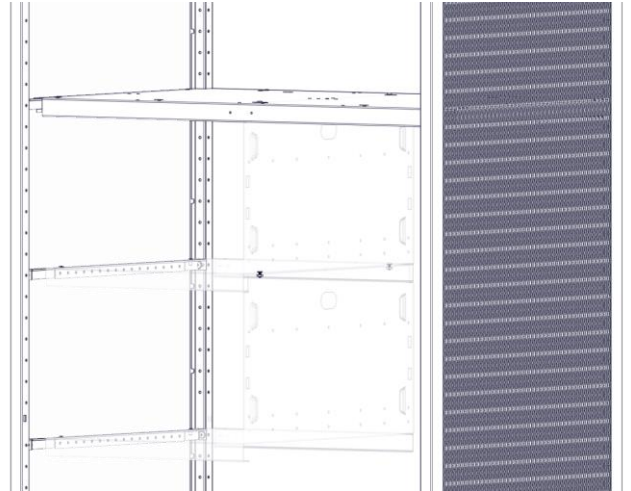
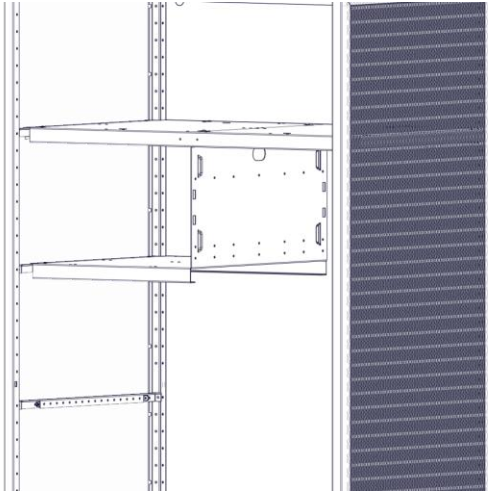

Installation of Inner compartment:

Step-3A Place plastic guide hubs into the inner compartment door holding it in place at the bottom until it is located in the correct position on the L or half shelf. 3B Insert the locking pins into the hubs in the top and bottom locking the door in place. 3C Install doorknob with screw on the backside of the door. 3D Install lock by placing it from the backside with the screws entering from the front in the provided holes and install nuts on each screw.

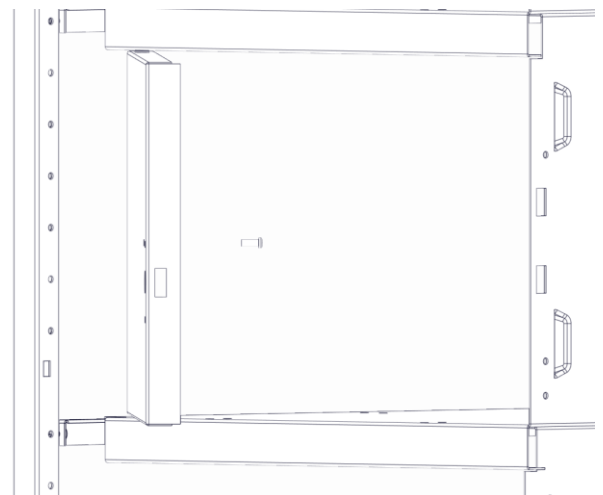
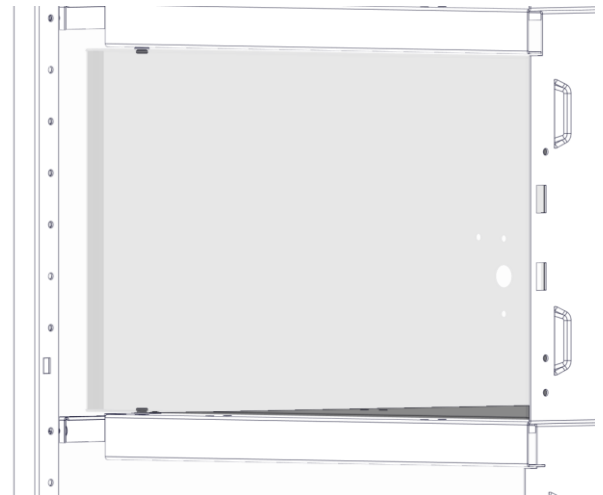
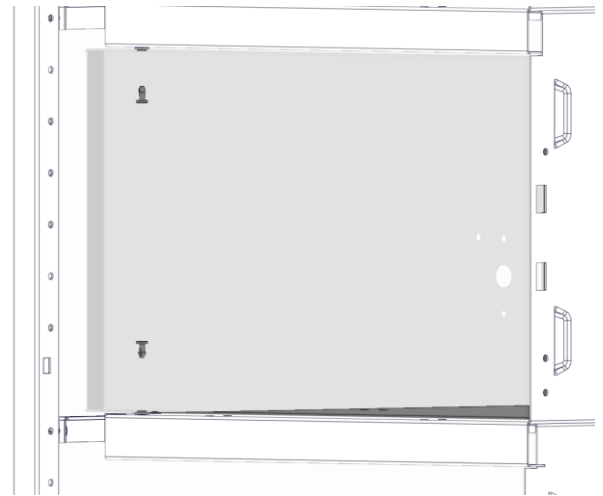
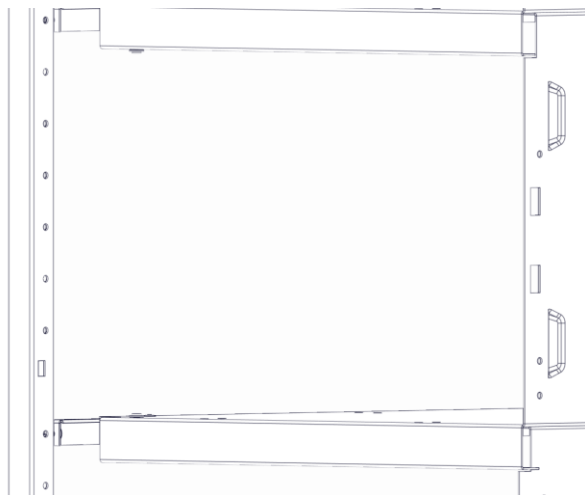
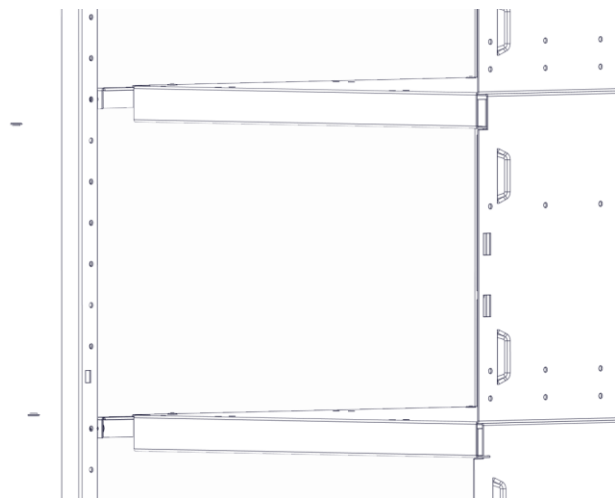

Fully Framed Accessory Assembly Instructions

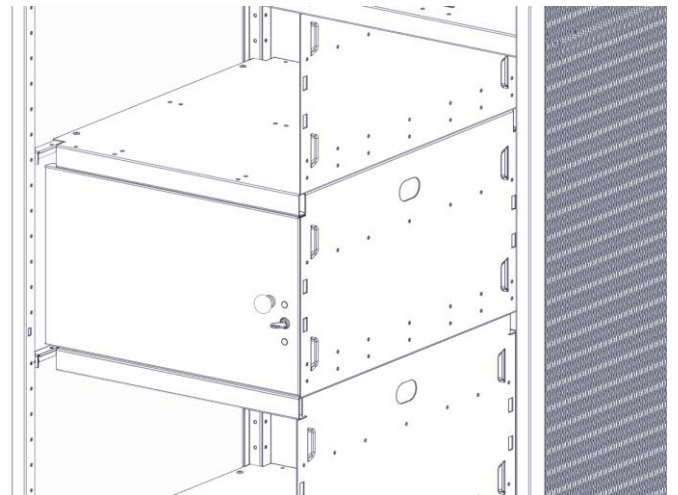
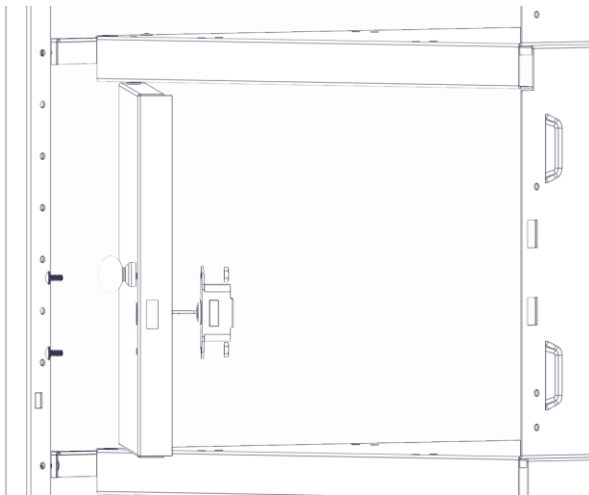
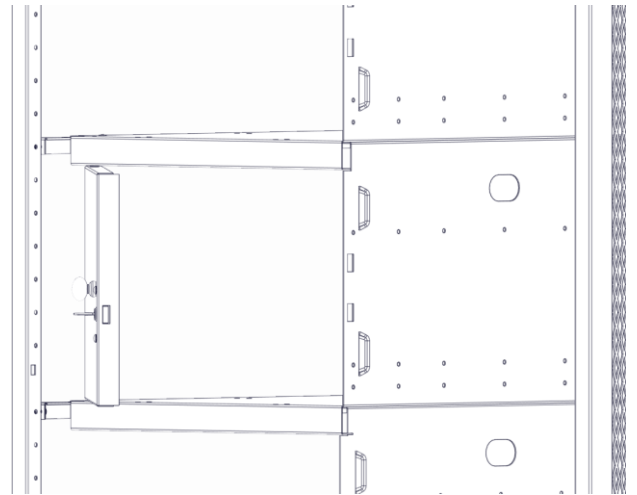
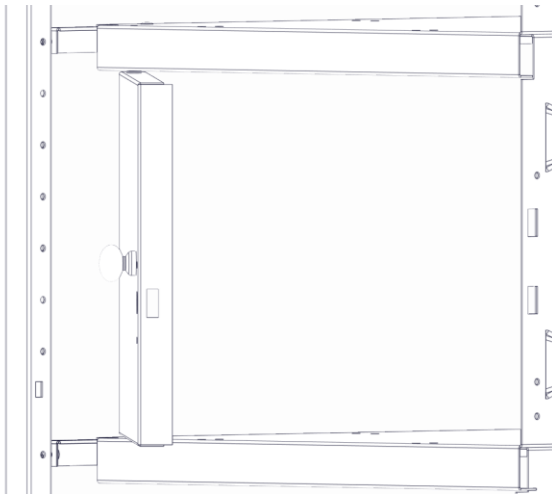
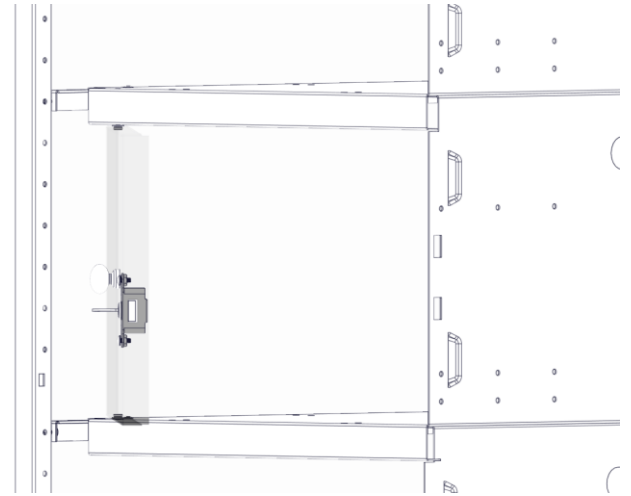
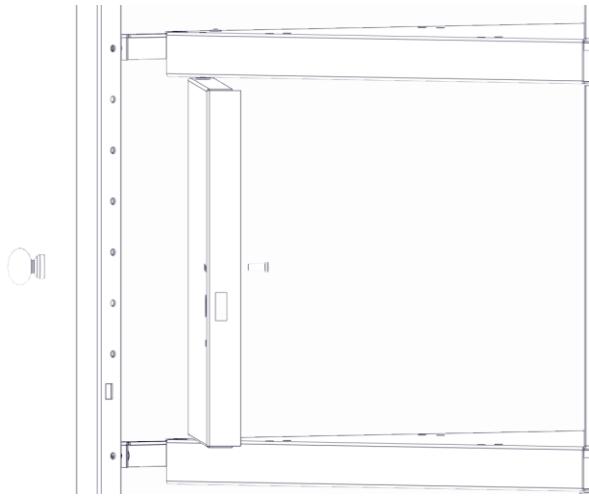

Fully Framed Accessory Assembly Instructions



To hide contents of, the inner compartment because the side is perforated install side cover. Install as shown using two rivets on the bottom and two screws on the top.

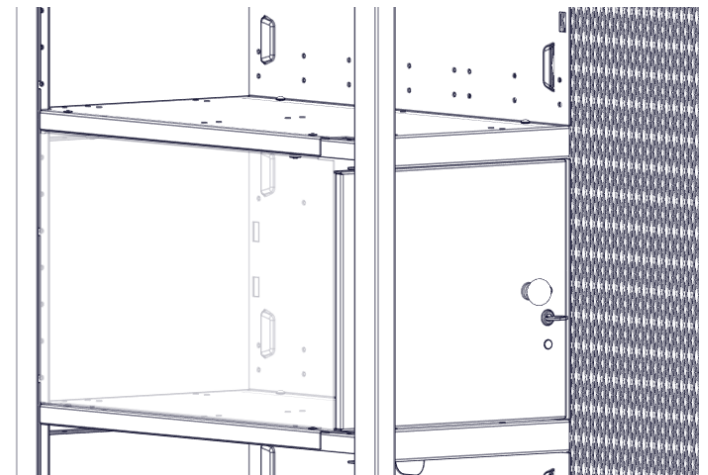
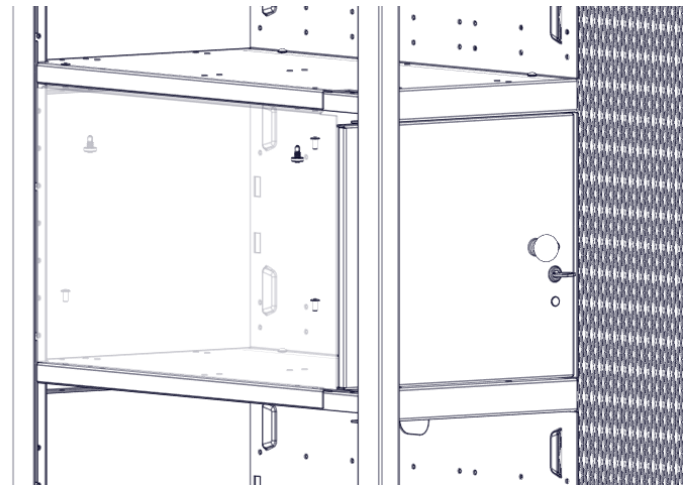
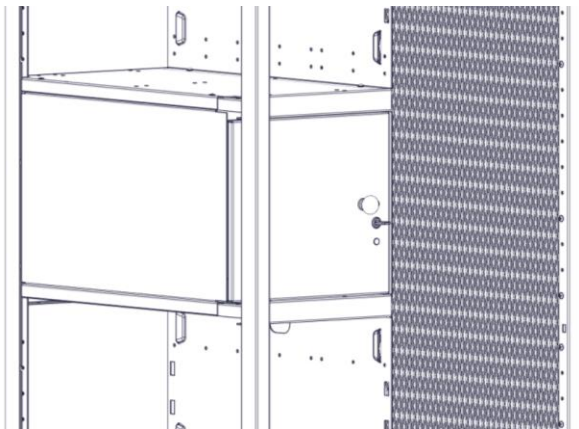
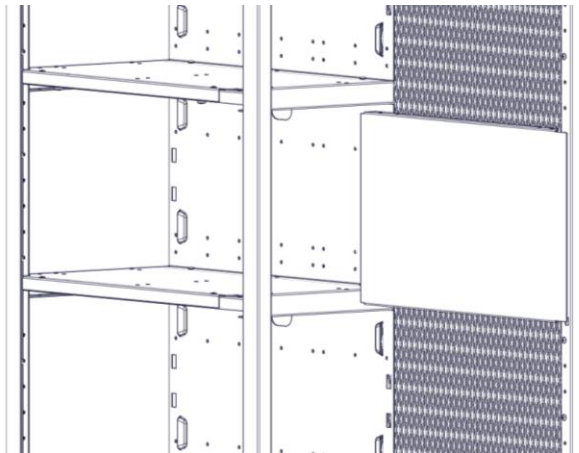

Install center partition

Step-4A If full width coat rod is installed remove one side to allow coat rod to go through center partition hole. 4B Place center partition in correct location under the shelf and install the required rivets or nut and bolt. 4C Align bottom of partition in correct location on lower shelf or bottom. If a lower shelf is used, install with rivets or nut and bolt. If no lower shelf is used then install with self-tapping screws. (There are no guide holes on locker bottoms.)

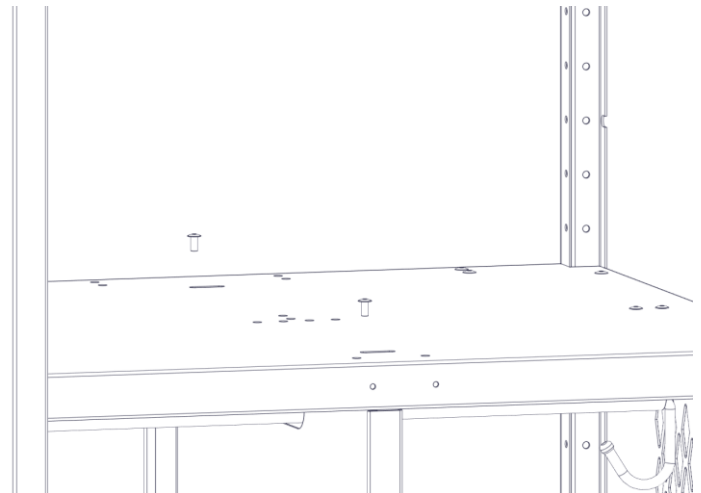
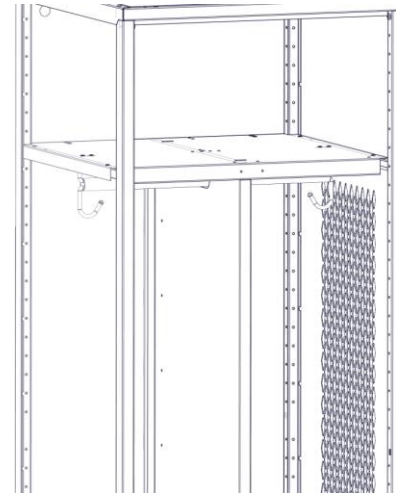
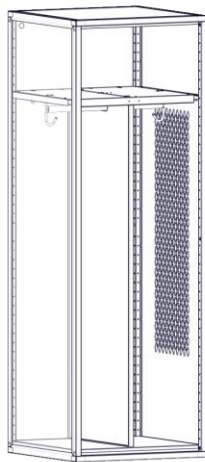
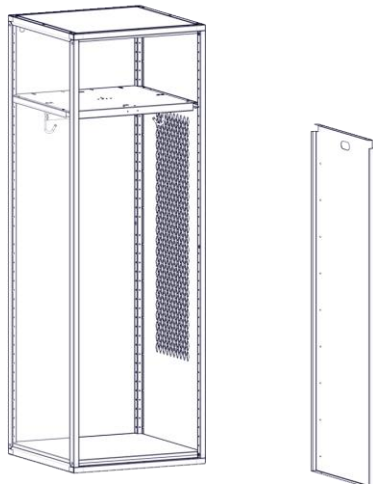

Fully Framed Accessory Assembly Instructions

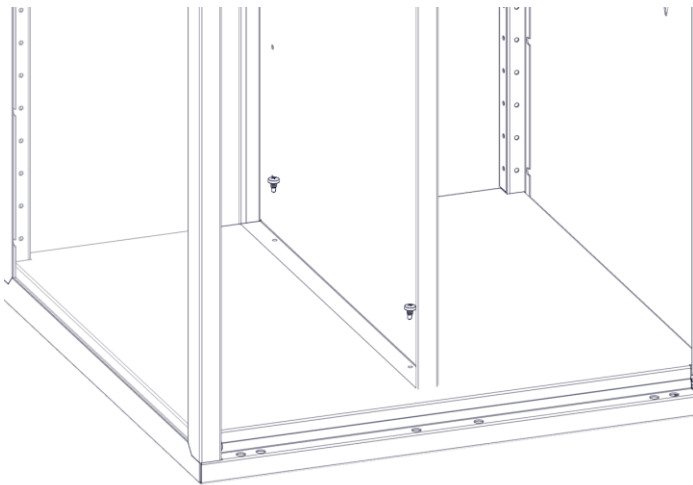
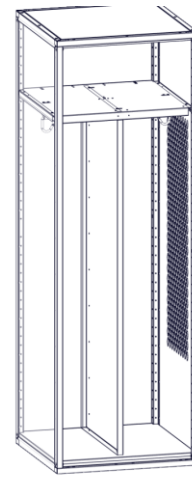
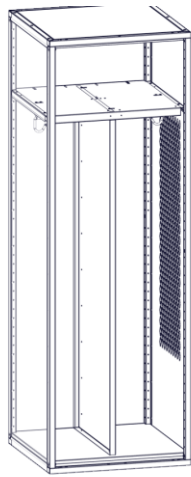
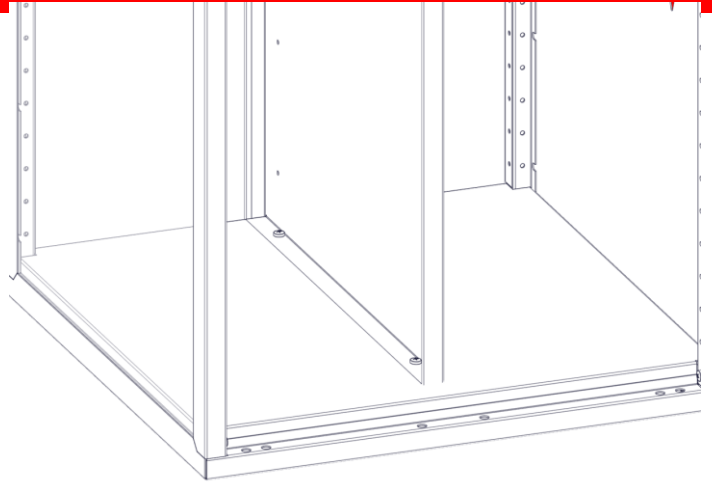
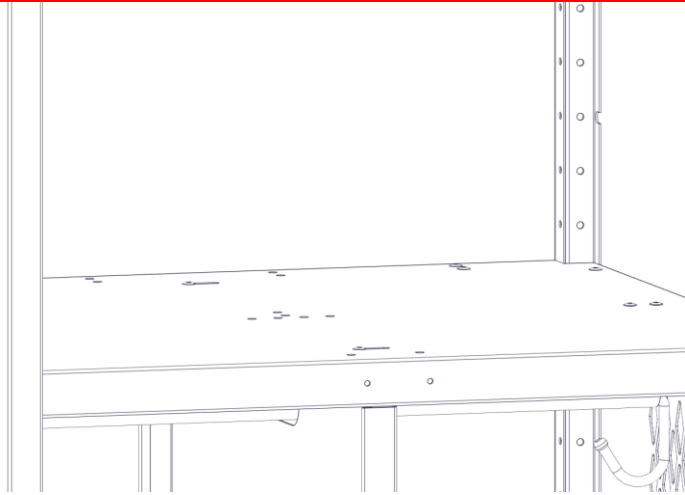

Installing a half shelf.

Step-5A Install half shelf support rail at the proper height location using one screw into each vertical upright. 5B Place half shelf on top of support rail, locate on shelf above, and insert four rivets to hold in proper location.

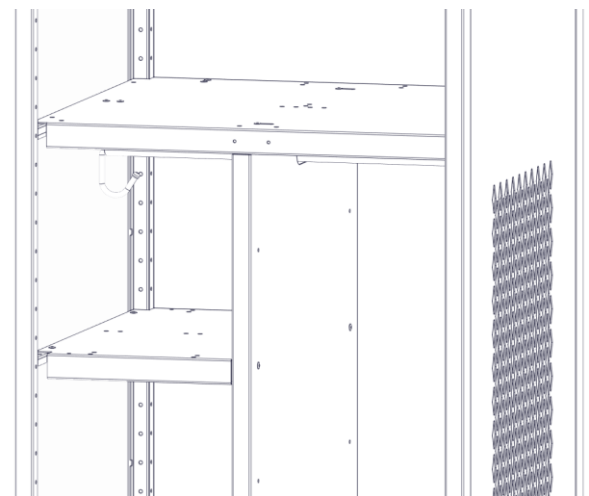
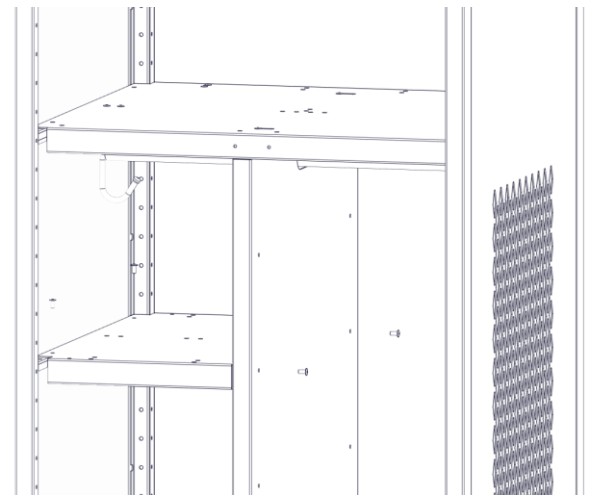
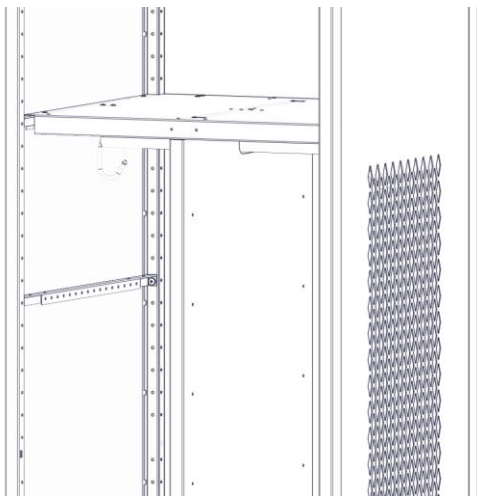
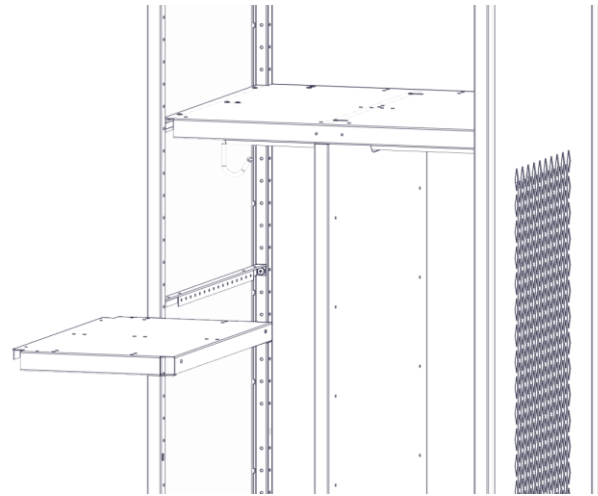
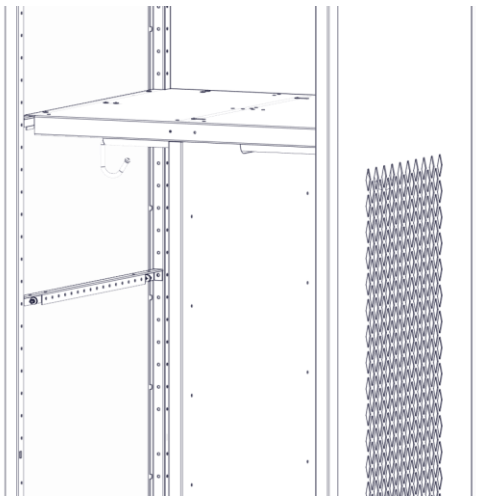

Installing 6" drawers

Step-6A Install shelf at desired location for first drawer. 6B install mounting rails for drawer using the 8709 screws provided. 6C Install drawer guide rails using two rivets attached to mounting rails. 6D Install plastic glide rails to drawer guide rails using the provided screws. Then insert drawer onto the glide rails.

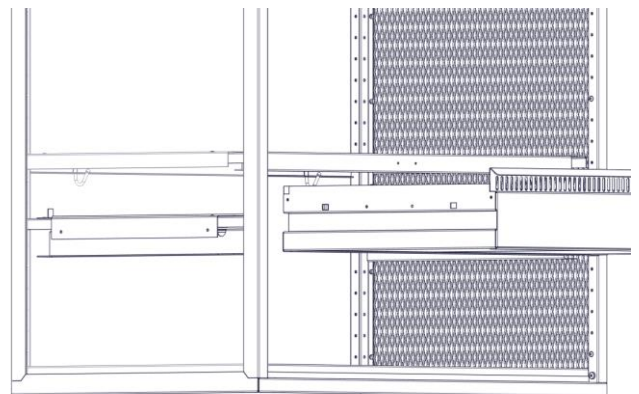
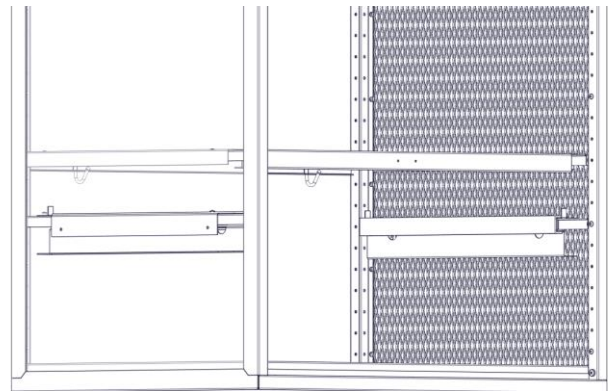
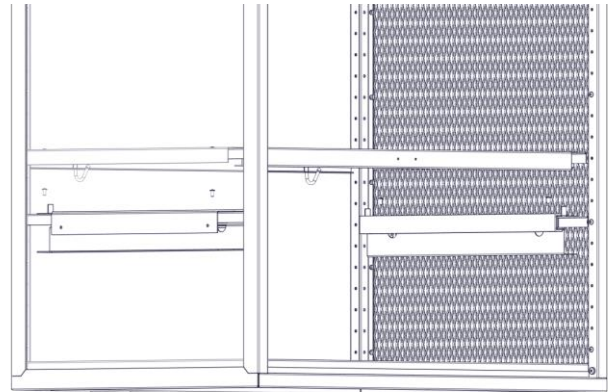
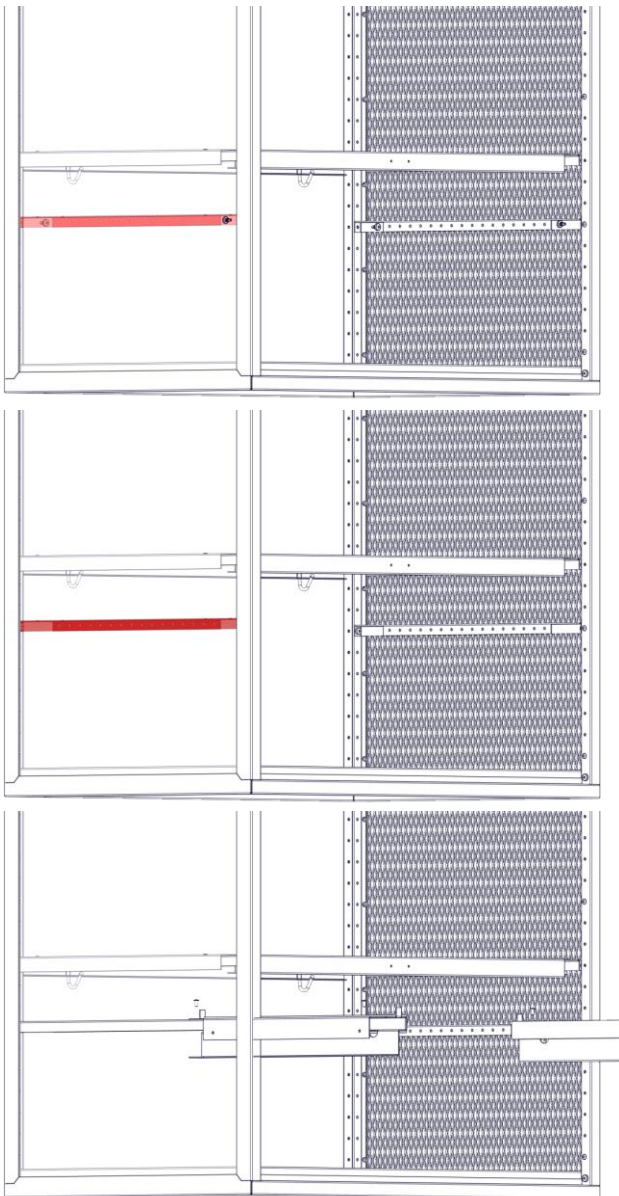

Fully Framed Accessory Assembly Instructions

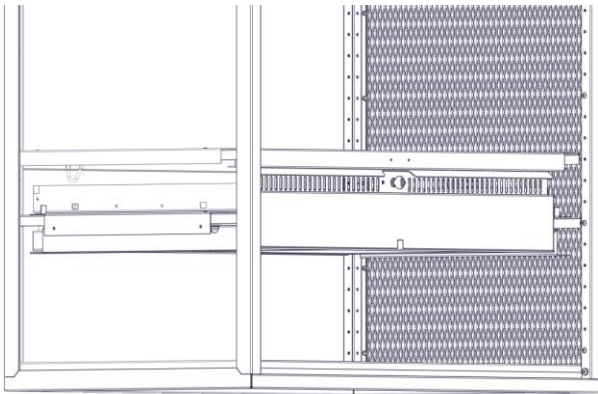

6E Install mounting rails for next drawer using the 8709 screws provided. 6F Install drawer guide rails using two rivets attached to mounting rails. 6G Install plastic glide rails to drawer guide rails using the provided screws. Then insert drawer onto the glide rails.

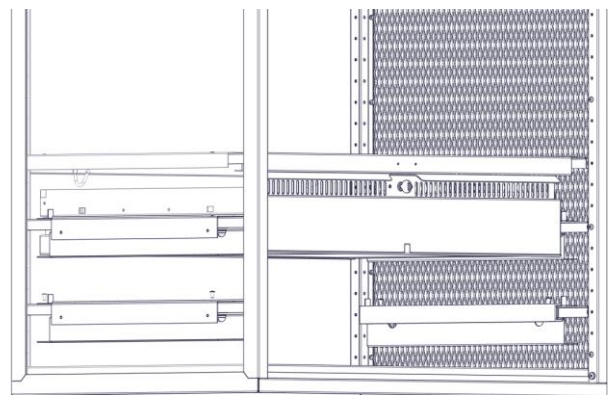
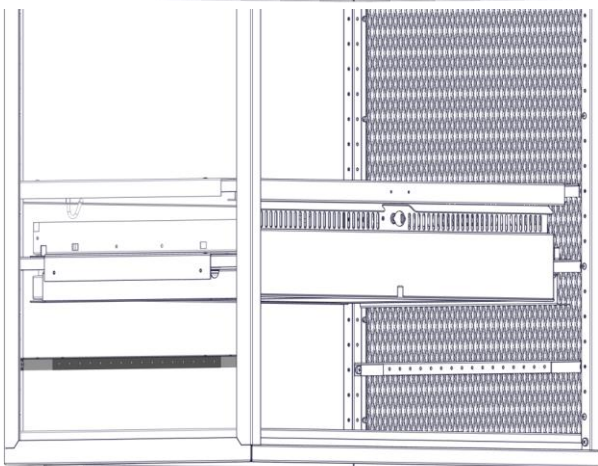
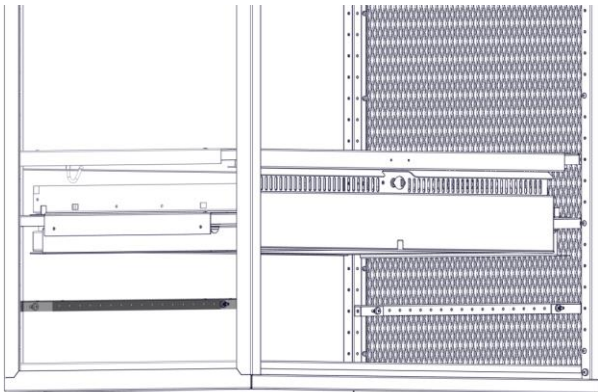
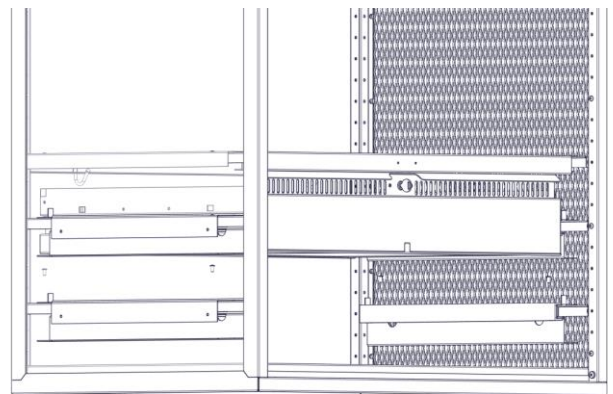
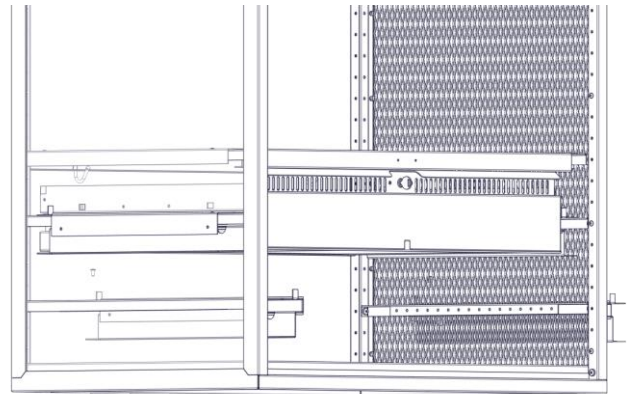

Fully Framed Accessory Assembly Instructions

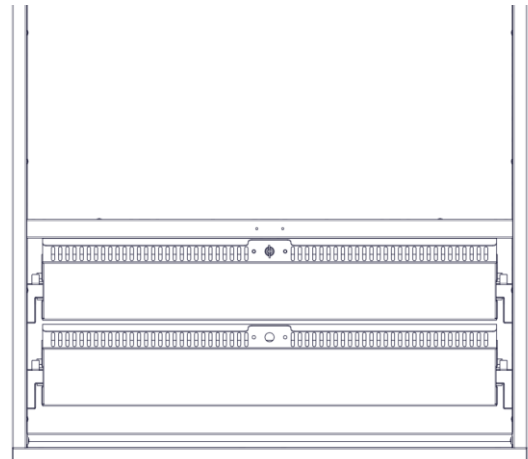
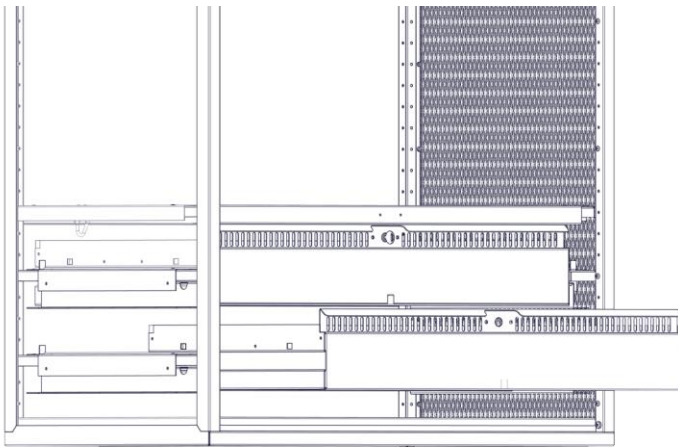
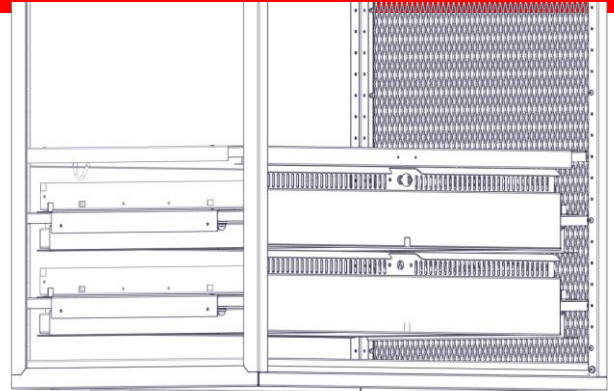
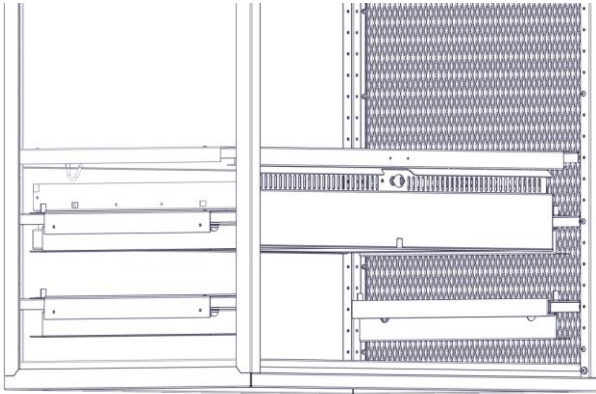

Installation of side-by-side drawers

Step-7A Install support rails for shelf at 13.9" up measured from the outside bottom. Install shelf on support rails using four rivets. Next install mounting rails for drawer using the 8709 screws provided. Next install drawer guide rails using two rivets attached to mounting rails. Install plastic glide rails to drawer guide rails using the provided screws. Next insert drawer onto the glide rails.

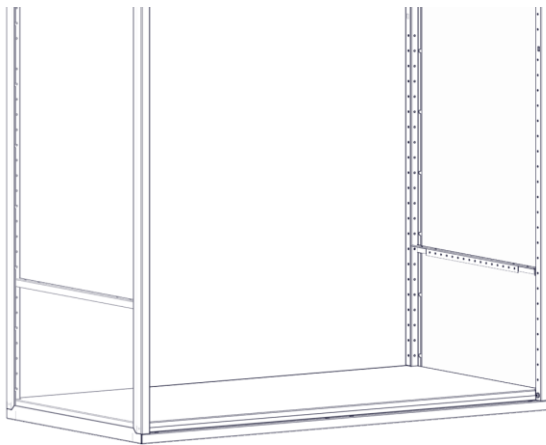
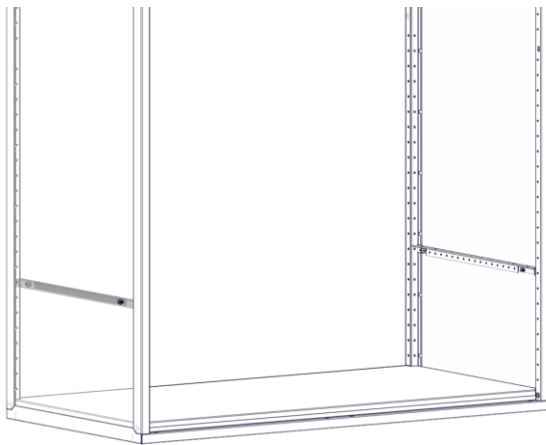

7B Install shelf on support rails using four rivets.

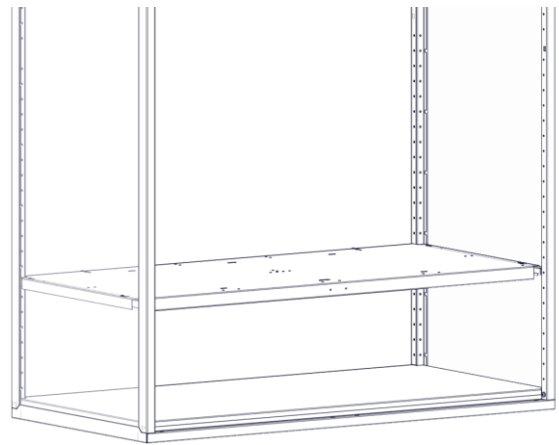
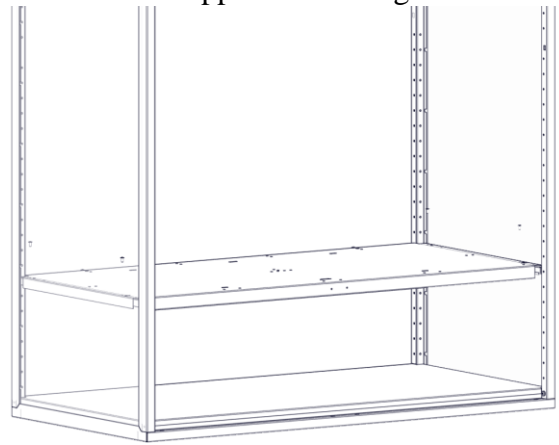

7C Install divider using rivets and screws. (Note it is critical to get this in the correct location for proper fit of side-by-side drawers.)

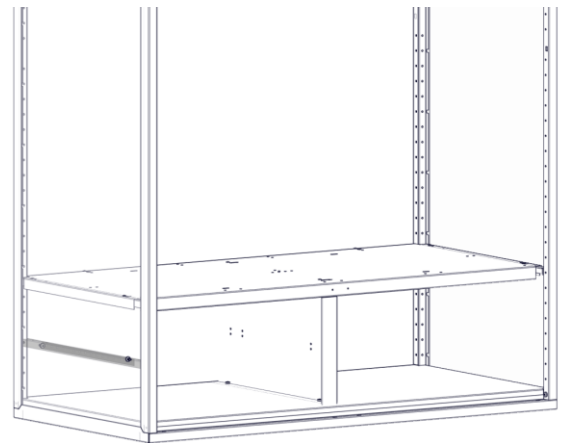
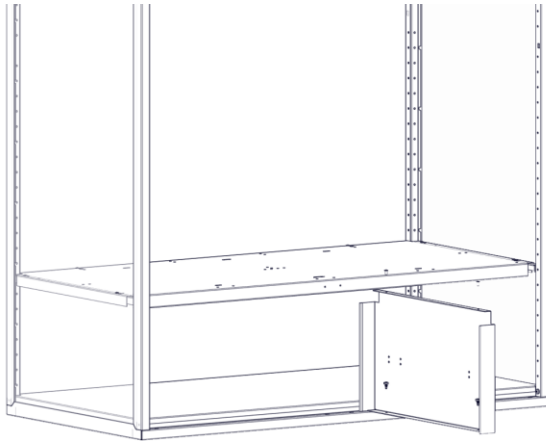

7E Install drawer guide rails using two rivets attached to mounting rail and divider.

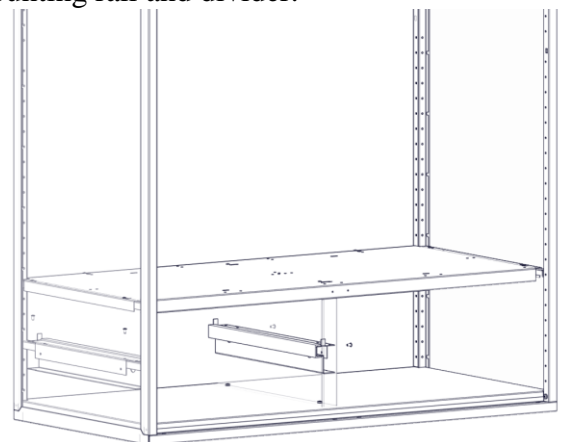
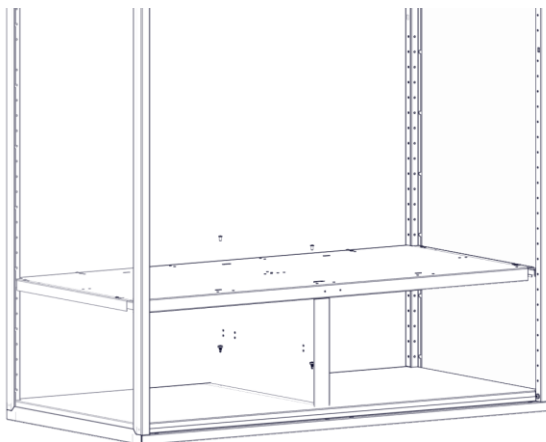

7F Install plastic glide rails to drawer guide rails using the provided screws. Next insert drawer onto the glide rails.

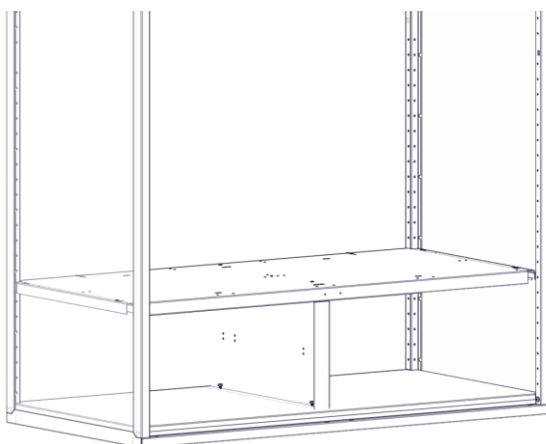

7D Install mounting rail for drawer using the 8709 screws provided.

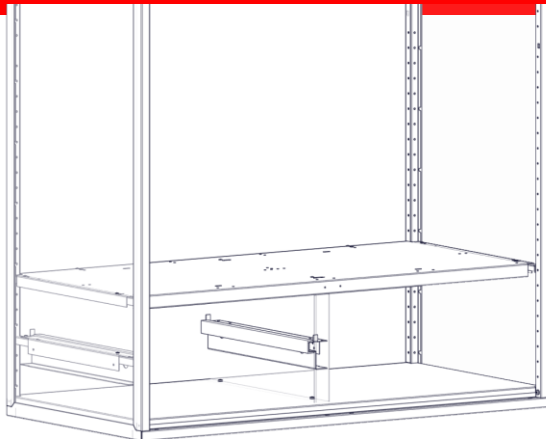

7G Install guide rail to divider using rivets.

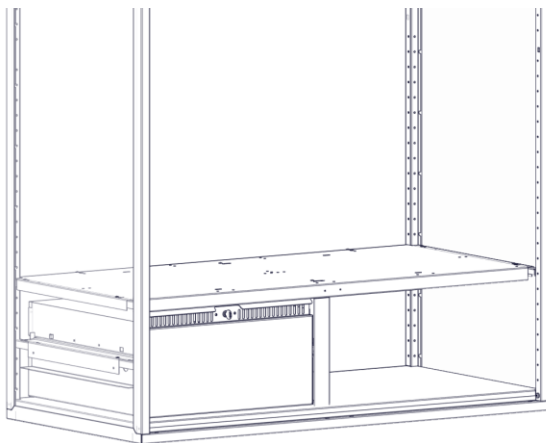
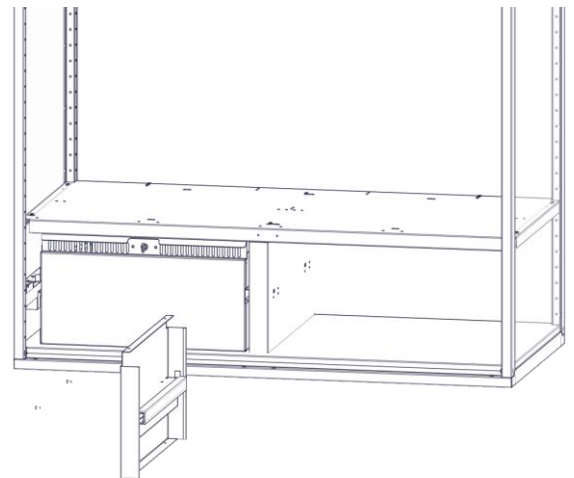
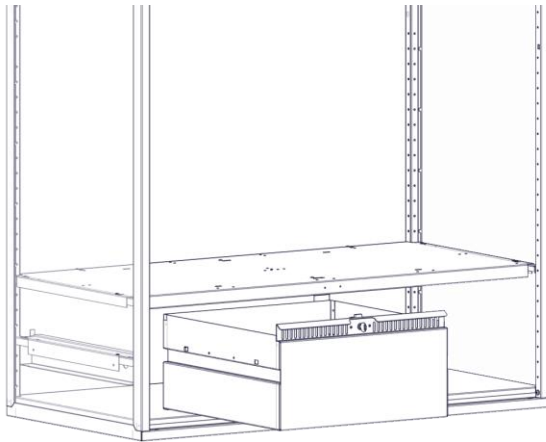
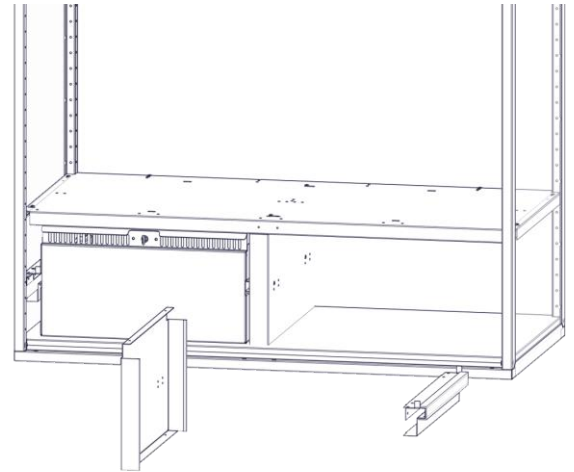

Fully Framed Accessory Assembly Instructions



7H Install divider using rivets and screws. (Note it is critical to get this in the correct location for proper fit of side-by-side drawers.)

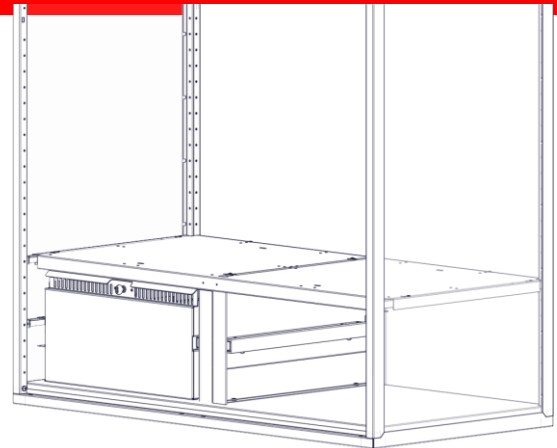
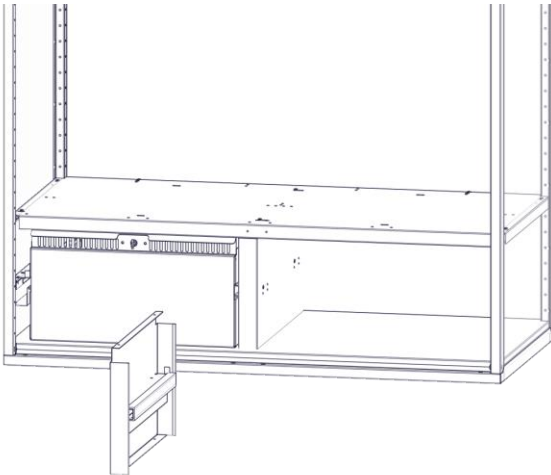

7I Install mounting rail for drawer using the 8709 screws provided

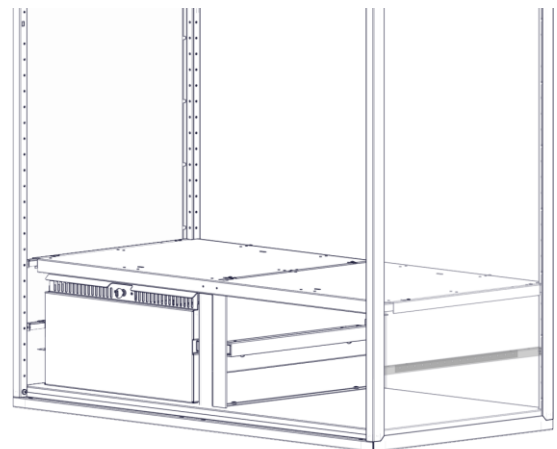
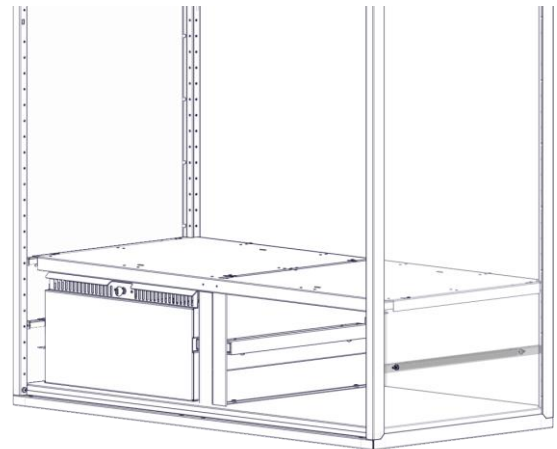
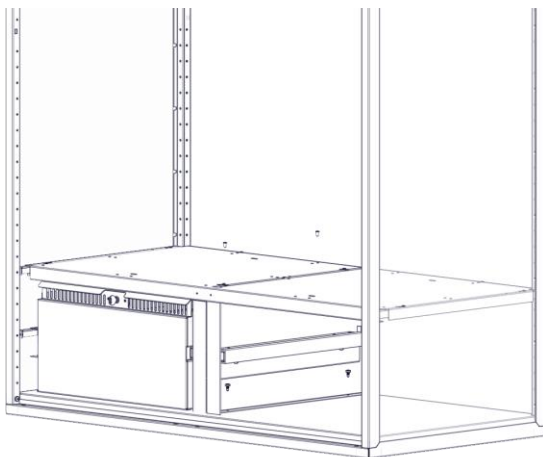

Fully Framed Accessory Assembly Instructions



7J Install drawer guide rails using two rivets attached to mounting rail and divider.

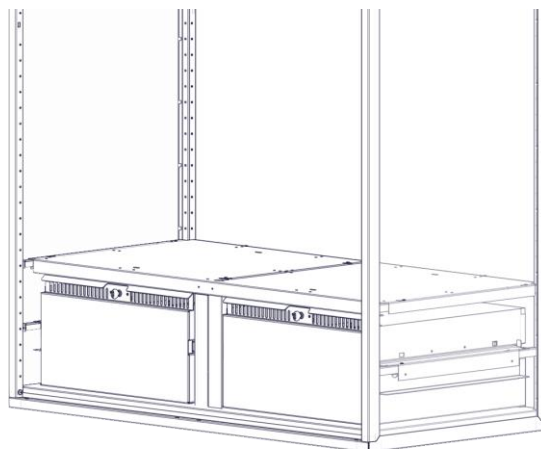
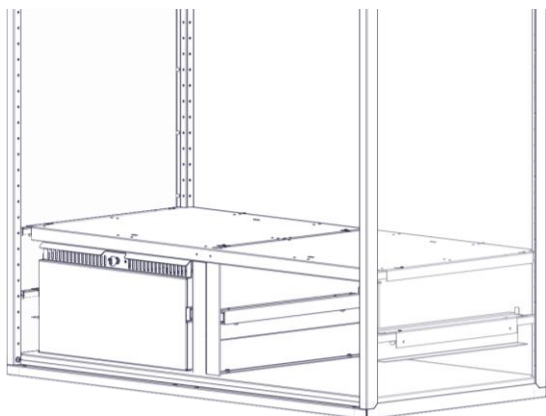
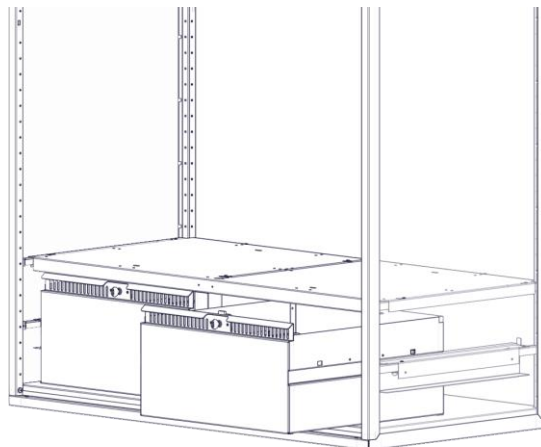
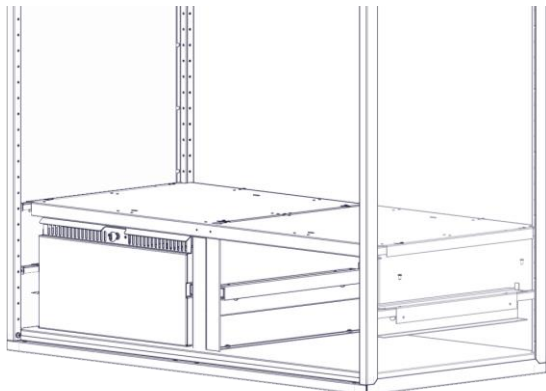

7K Install plastic glide rails to drawer guide rails using the provided screws. Then insert drawer onto the glide rails.

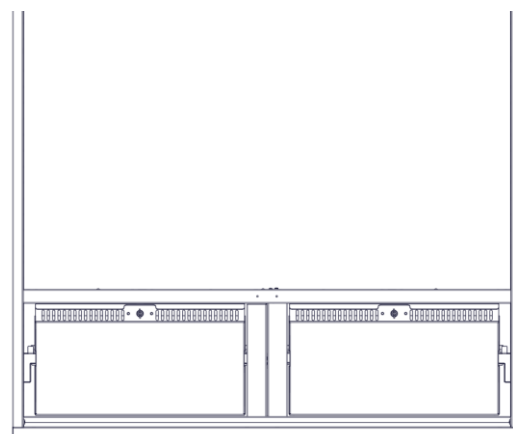

STEP 4- Install Footlocker

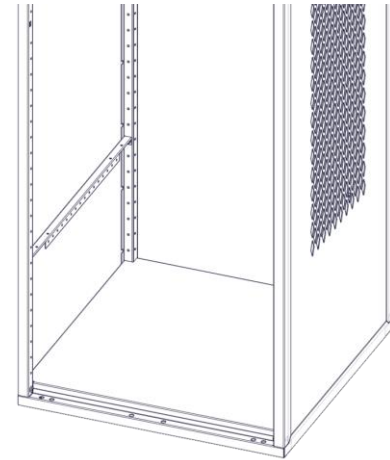
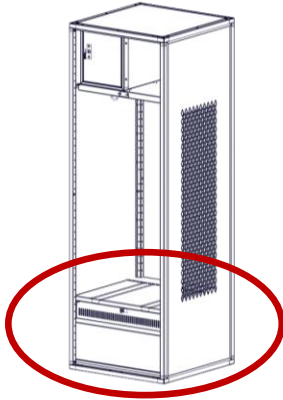

4A- Install the side mounting rails at the proper height locations using one screw in each corner. Rail height for footlocker is 13.9 inches from the outside bottom corner to the top of the rail. Two mounting rails required one on each side.

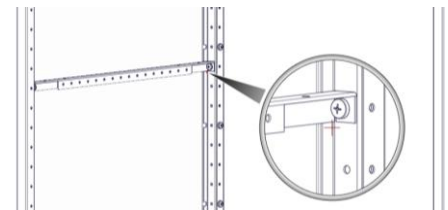
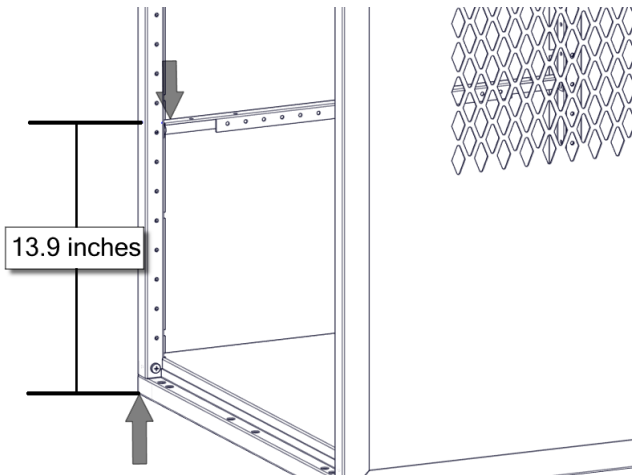
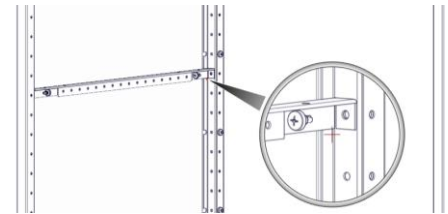

4B- Now install the footlocker front panel by inserting it behind the vertical corner posts and into the slots of the horizontal side rails and attach using four rivets.

Fully Framed Accessory Assembly Instructions

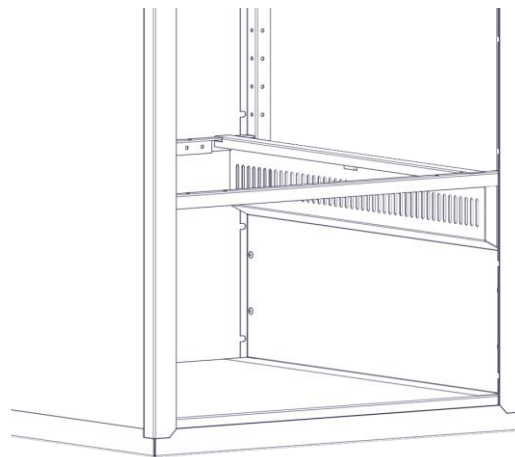
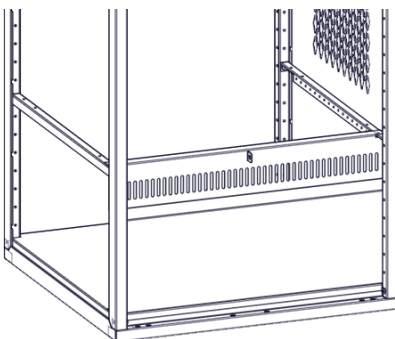
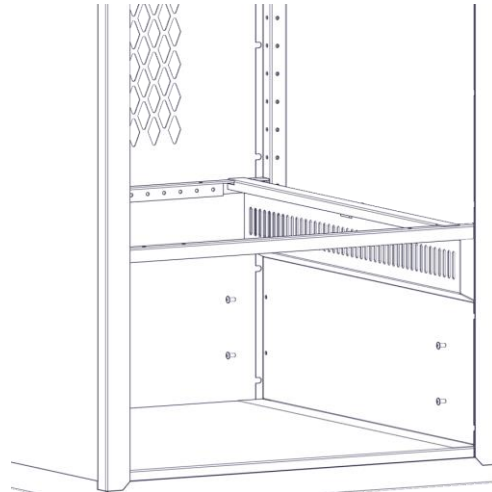
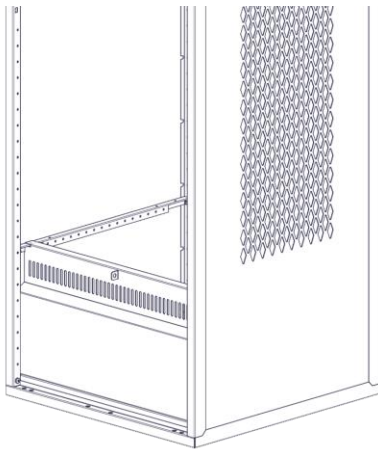
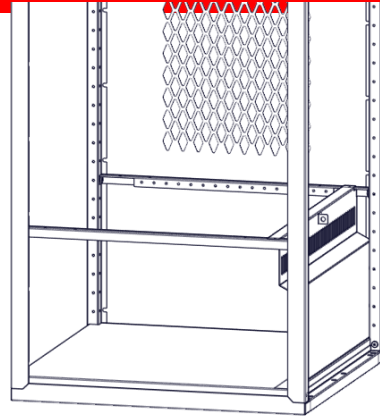
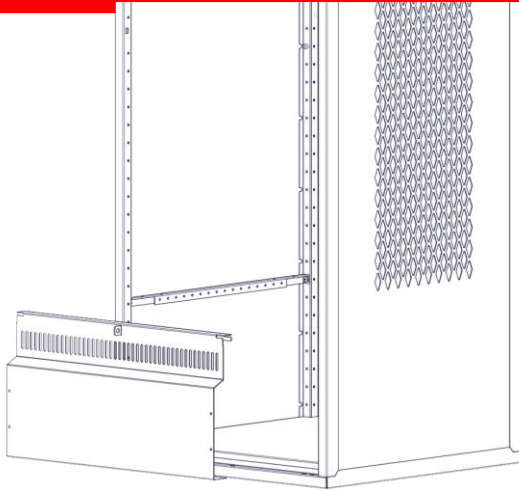

Fully Framed Accessory Assembly Instructions



4C- Next install the seat assembly using four rivets into the horizontal rails at the proper locations.

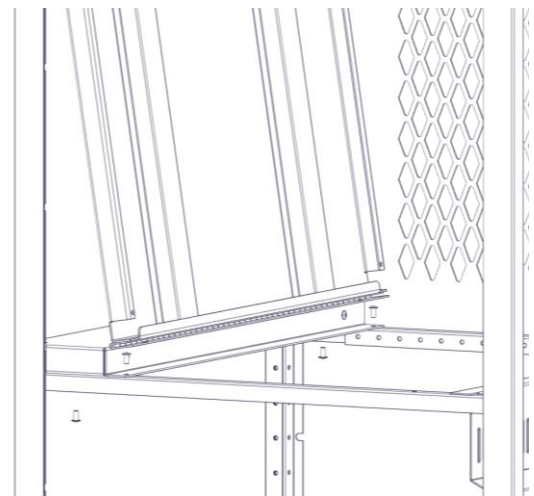
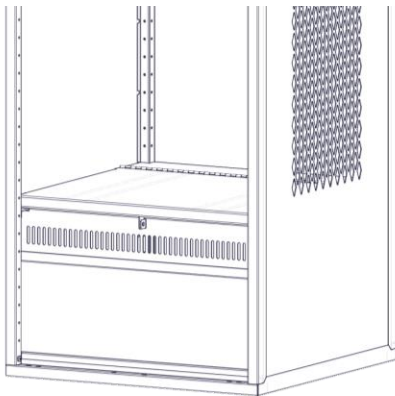
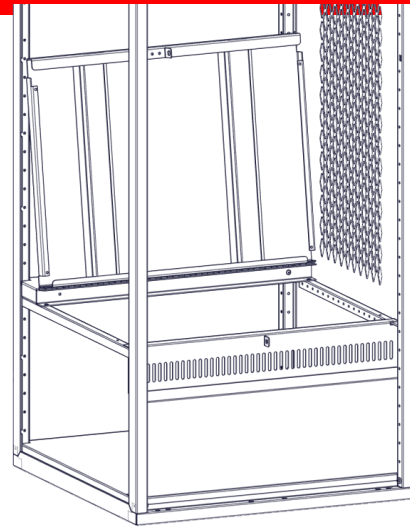
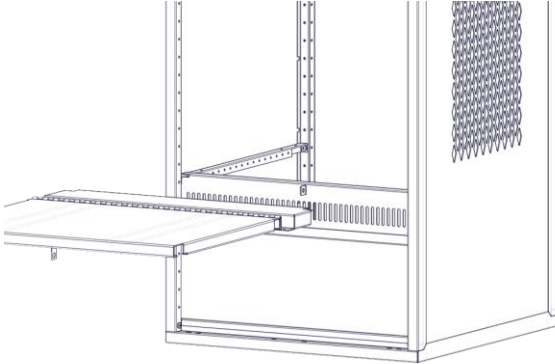

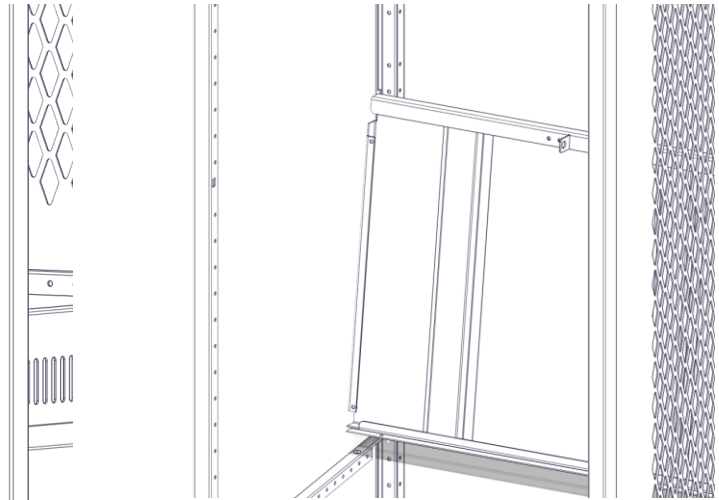
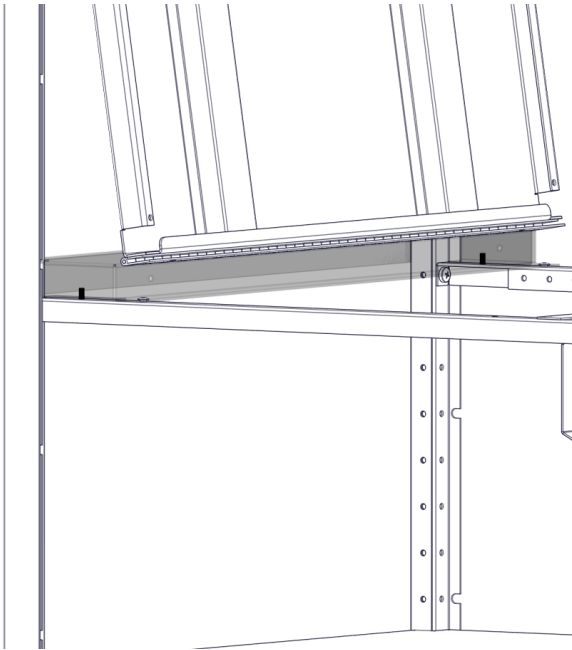

4D- Now install the rubber bumpers on the seat and at proper height on the vertical posts.

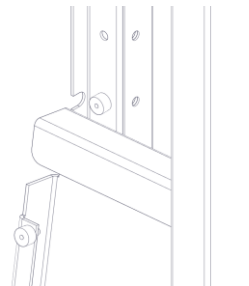
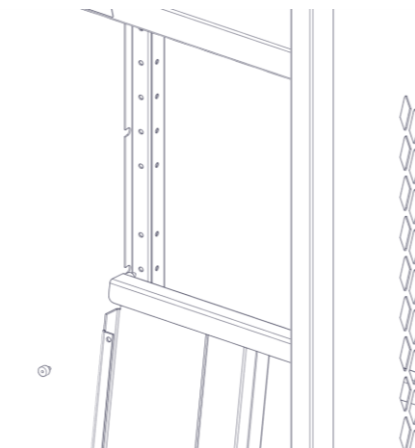
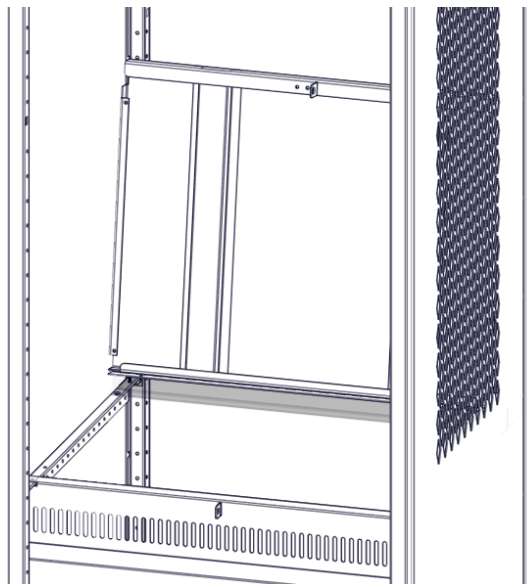

Metal or Wood Seat Installation

9A- Install the side mounting rails at the proper height locations using one screw in each corner. Rail height for 18-inch high seat is 16.9 inches from the outside bottom corner to the top of the rail. Two mounting rails required one on each side.

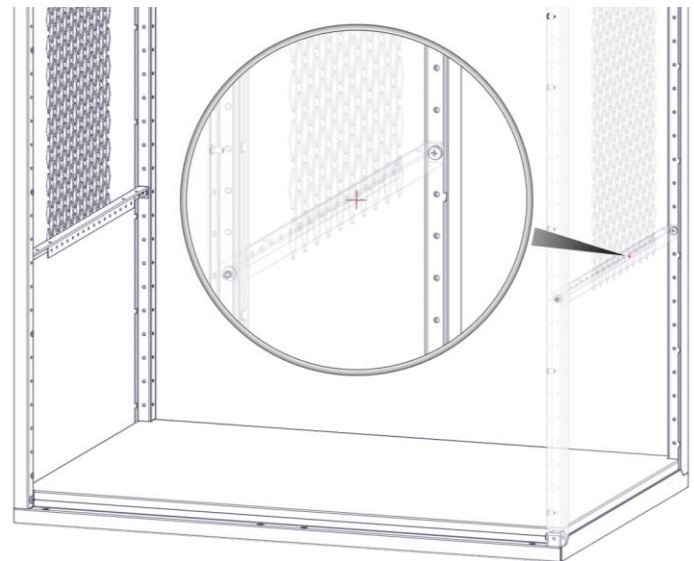
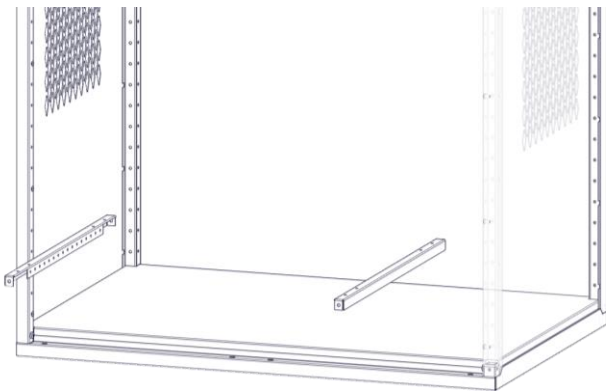

9B- Rivet seat to mounting rails in each corner as shown. For wooden seat install with lag bolts in each corner.

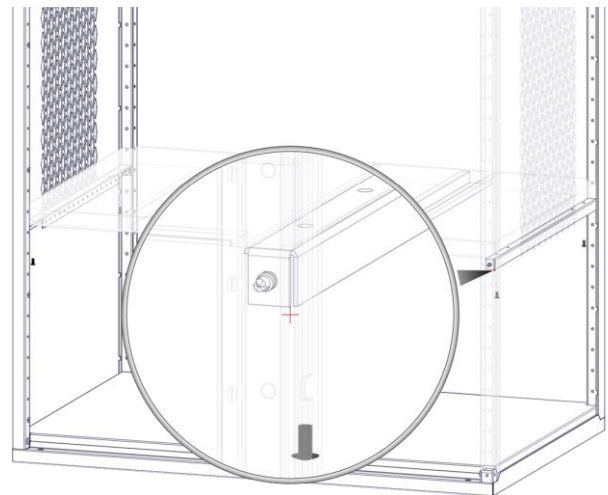
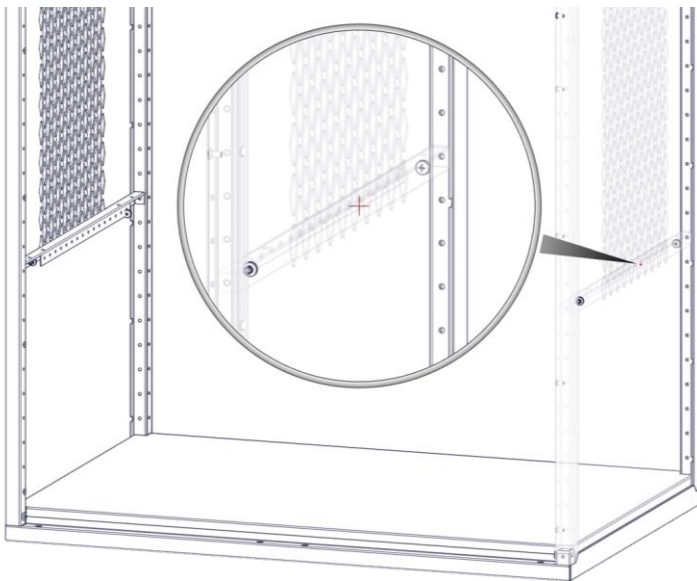

Fully Framed Accessory Assembly Instructions

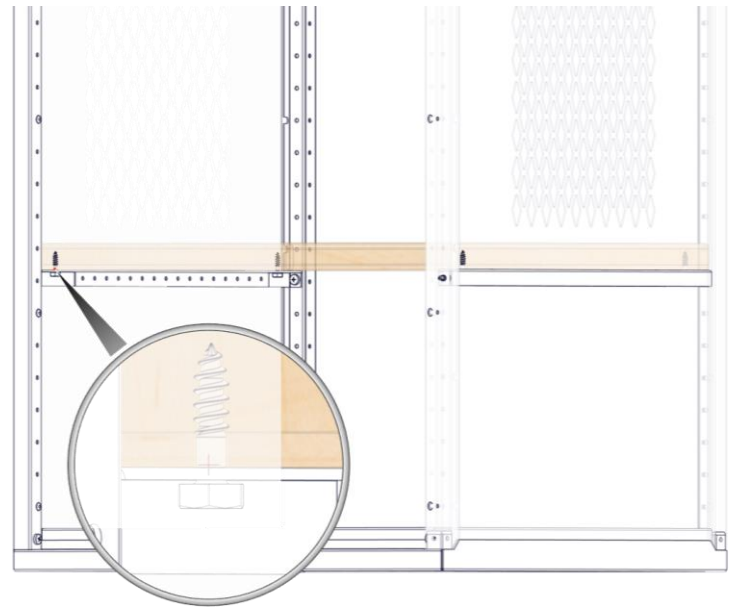
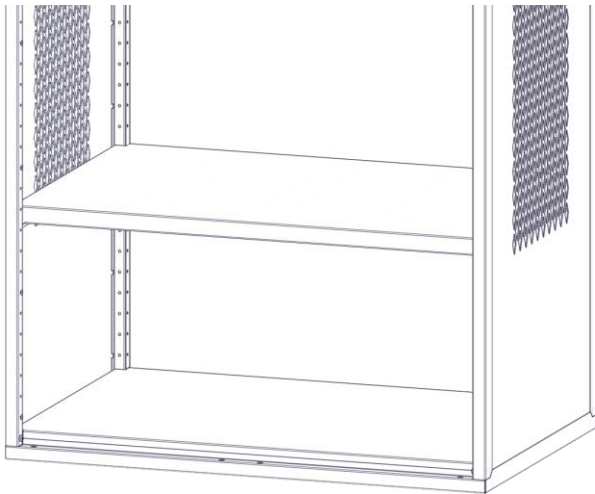
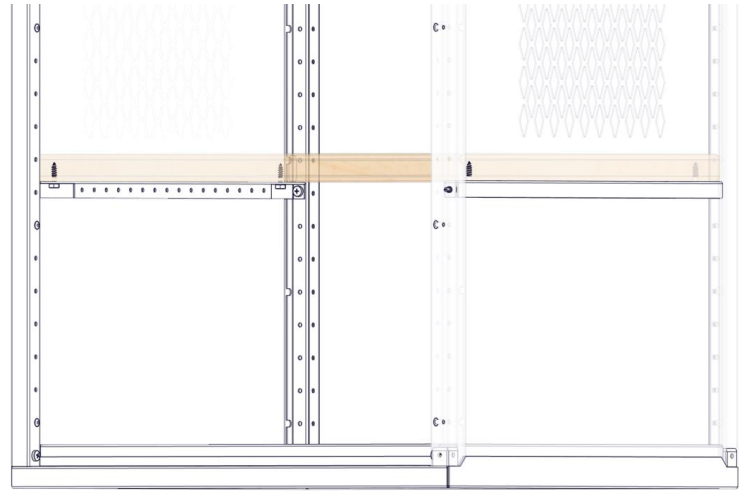
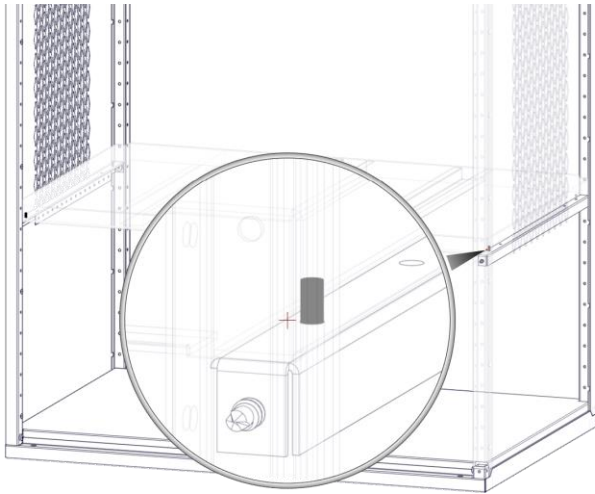

For wooden seat, add the lag bolts as shown.

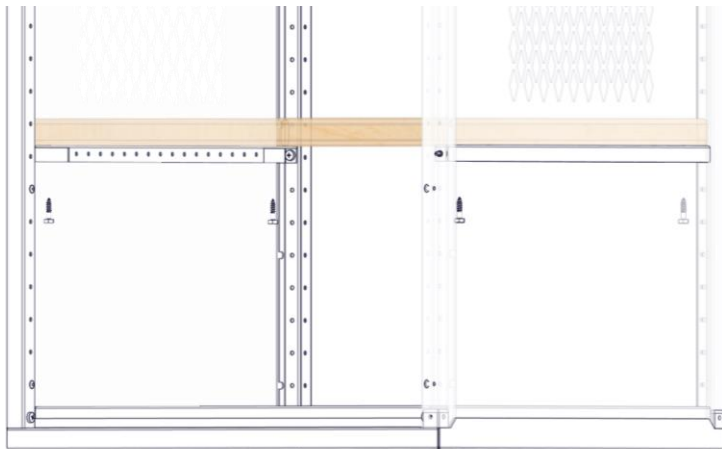

Channel Base Installation

10A- Install channel base by aligning in proper location and adding four bolts one in each corner.

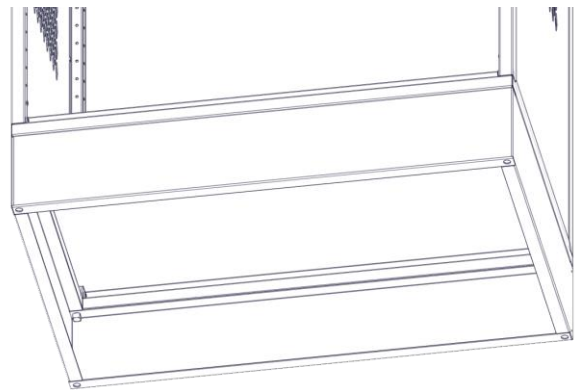
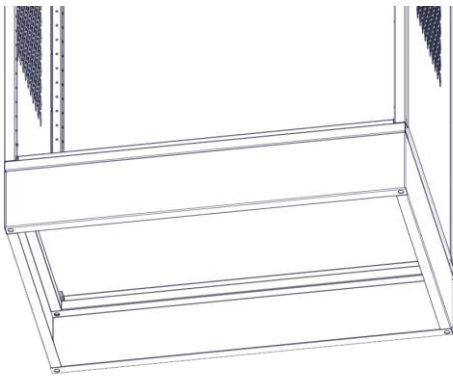
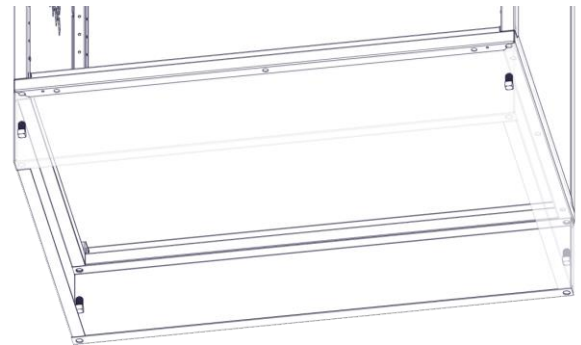
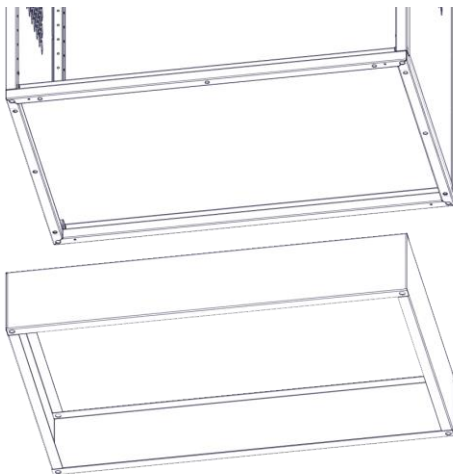
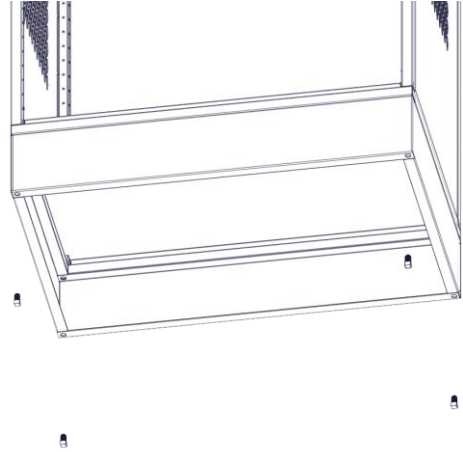
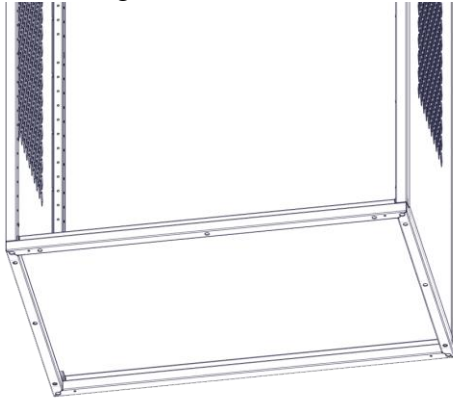

Document Sleeve Installation

11A- Install document sleeve by aligning in desired location and orientation and install with four rivets as shown.

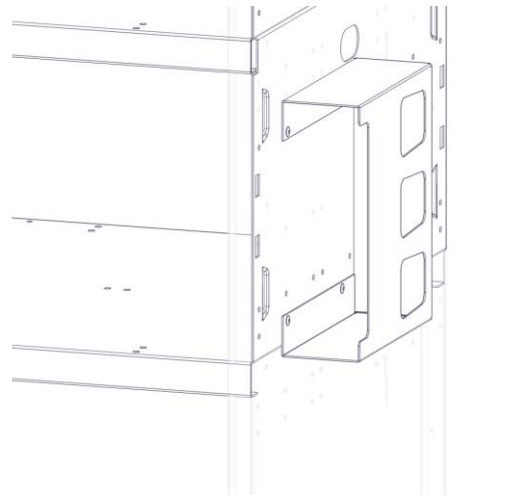
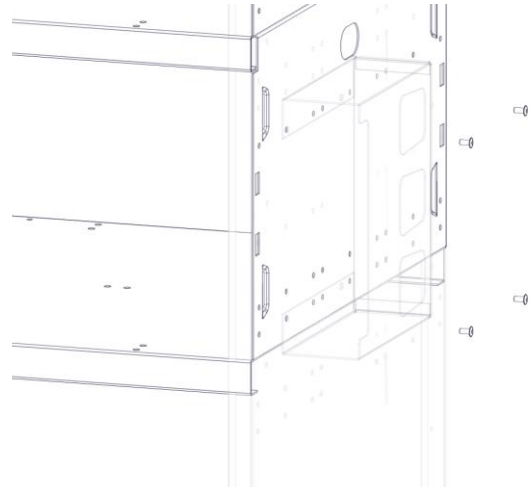
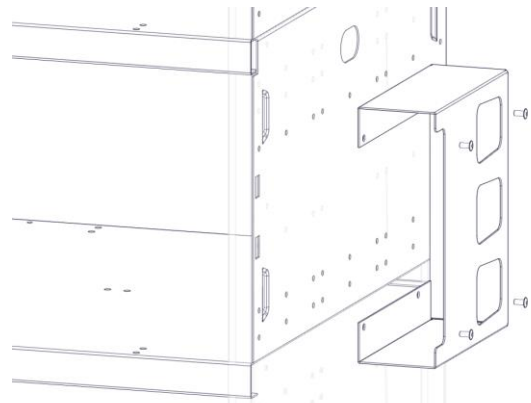
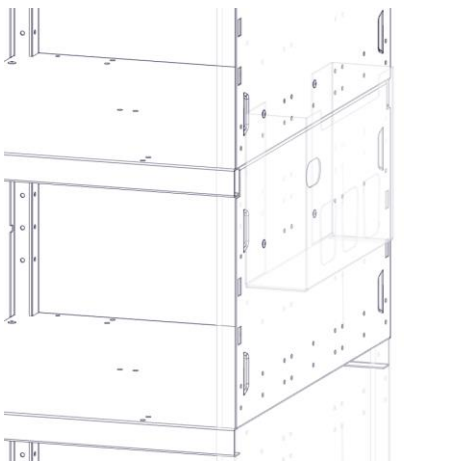
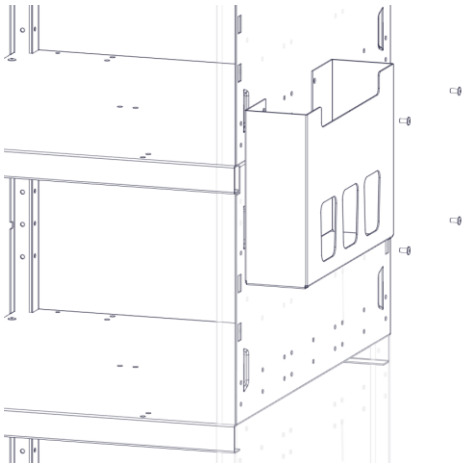
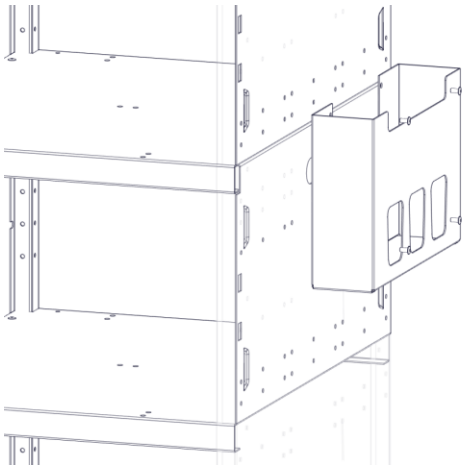

Cell Tray Installation

12A- Install cell tray by placing in desired position and rivet using two rivets as shown.

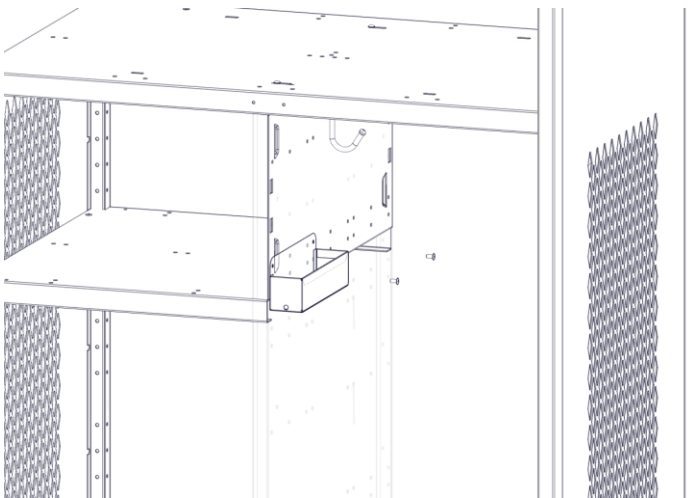
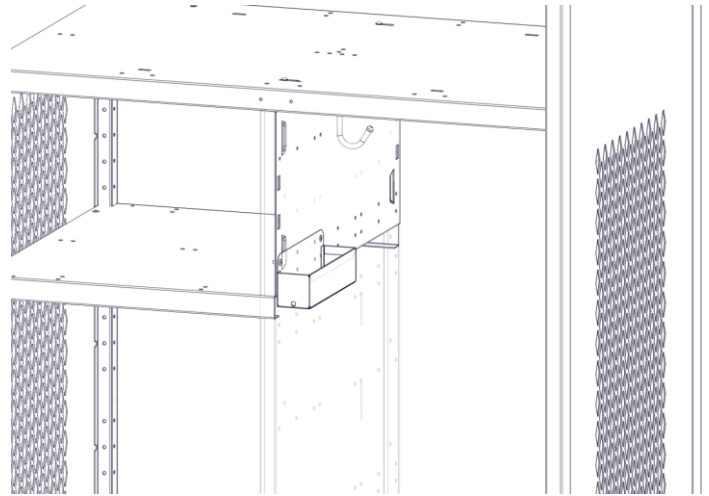
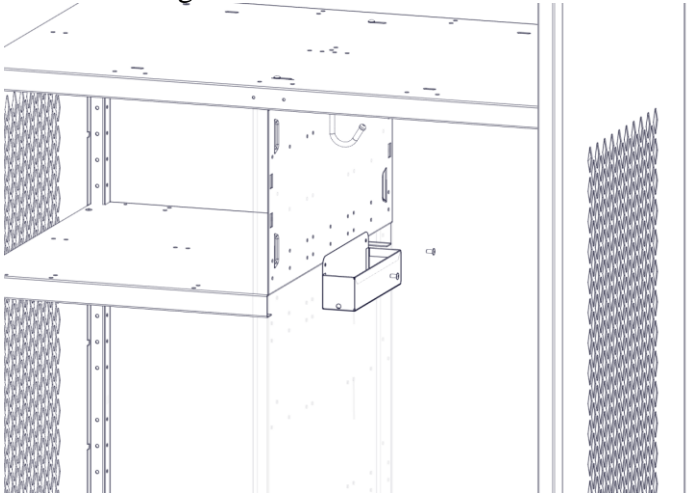

Coat hooks and Coat Rod Installation

13A Install 8717 coat hooks, and coat rod using two rivets per hook as shown. Note it is necessary to put coat rod in place while installing last coat hook.

