

Fully Framed Patriot Turnout LOCKER – KD

Assembly Instructions



Fasteners & Tools Needed

The following items are in the hardware kit shipped with the locker:

8615–Number plate



8671–Aluminum Rivet



8621- Steel rivet

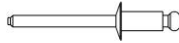

8709-Screw



..

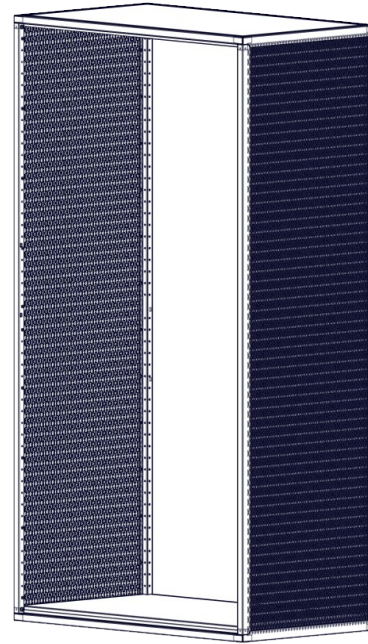

STEP 1- Check Parts

Unpack the component pieces for the basic locker. You should have two sides, a back, a top, and bottom, for the locker body. You should also have a left hand and a right hand door.

You will need these tools to assemble the Patriot Turnout locker.

Rivet gun.

Drill with #3 Philips bit



Flat blade and Phillips head screwdrivers.

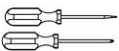

Stepladder

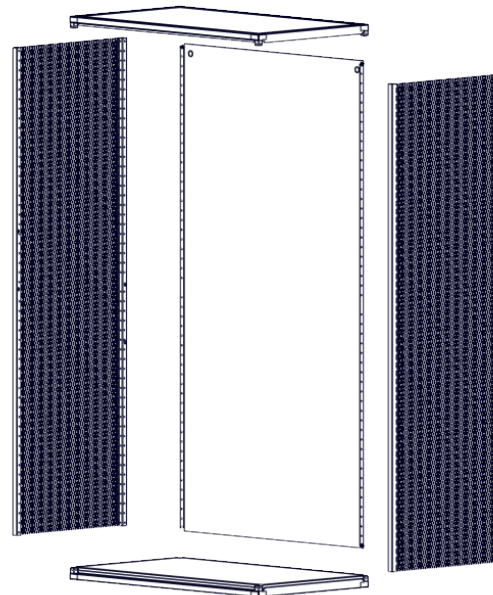

Note- Assemble locker upside down to allow screw insertion into underside of locker bottom. Images shown may differ from your locker, as there are different configuration options. Some parts show with transparency in these instructions to add clarity to assembly.

STEP 2 – Assemble the locker body

2A- Lay locker top on flat surface on the ground. Insert the two sides onto the cast corner pieces of the top assembly.

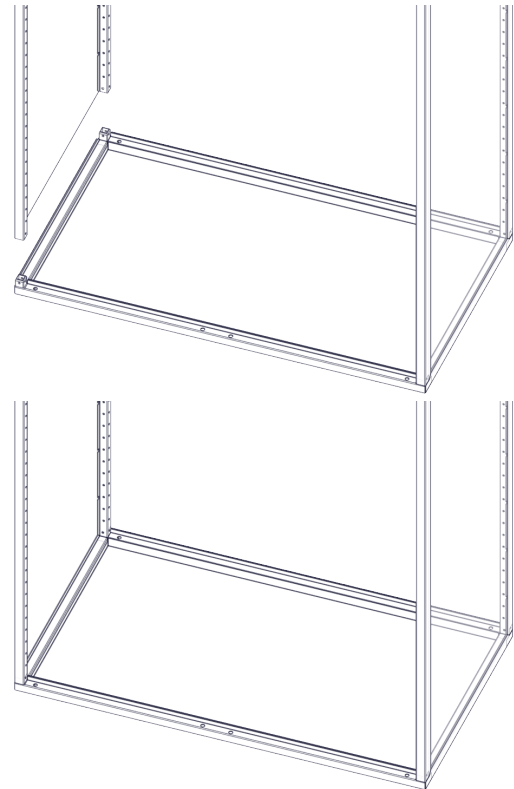
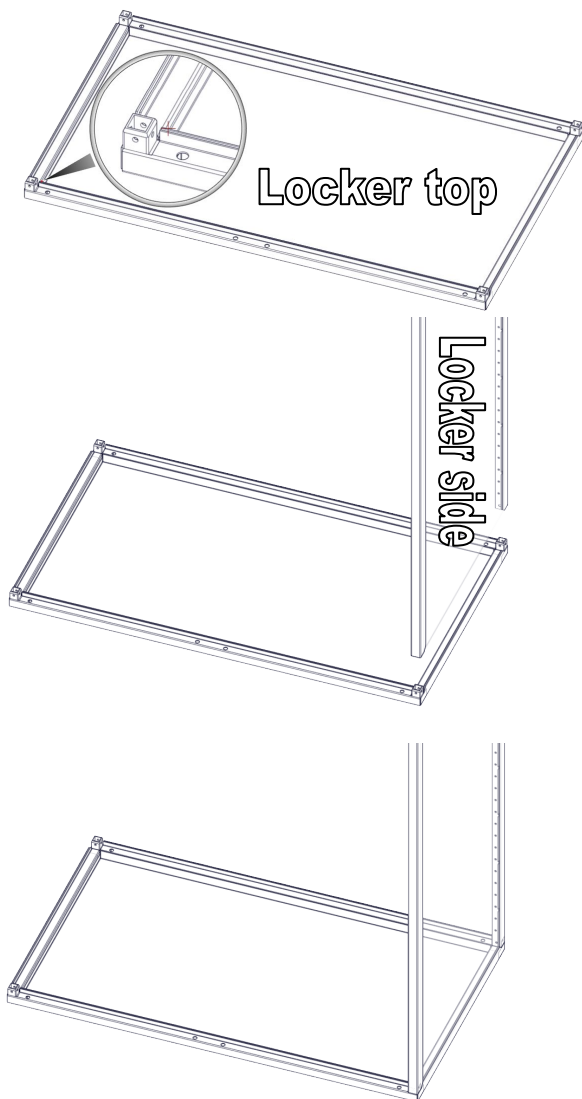

2B-1 Insert locker back into slot of the top.

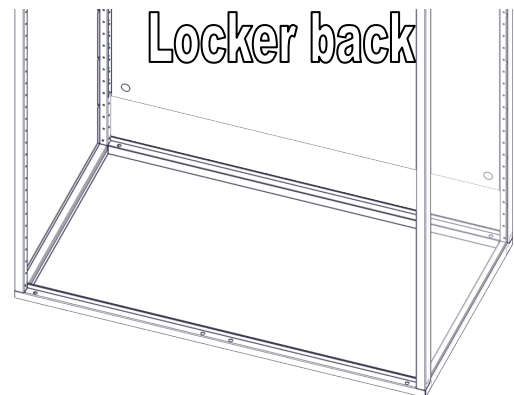

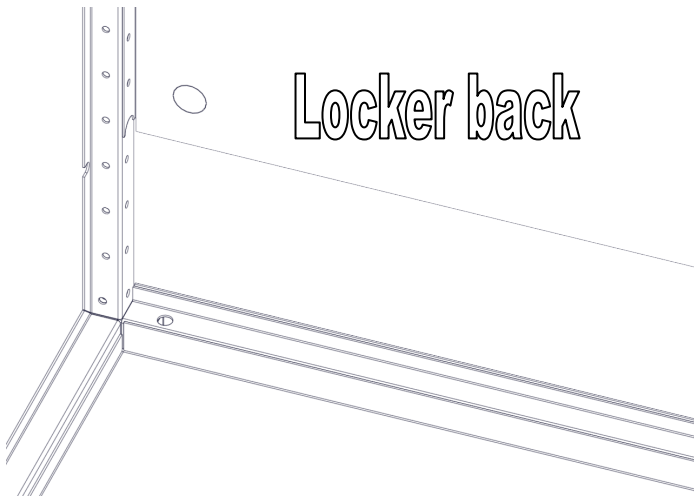

Locker back

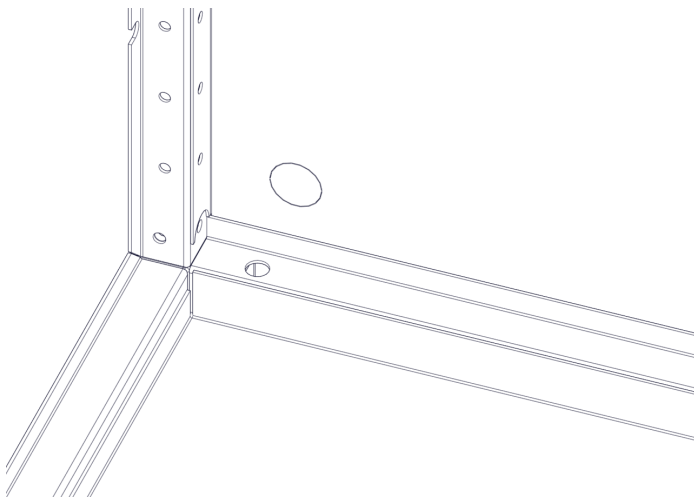

2B-2 With the back inserted install one 8709 screw on each side of the back about half way up. Note holes are to align to make sure back is in proper position.

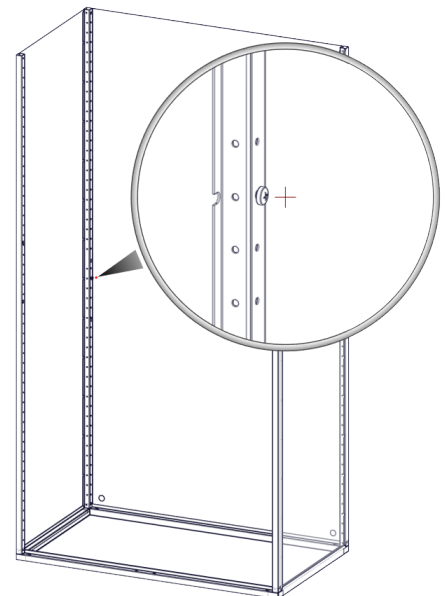
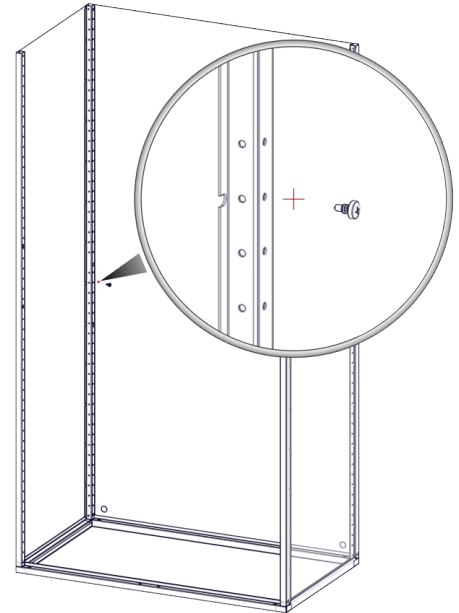

2C-1 Insert cast corner pieces of locker bottom into the side channels.

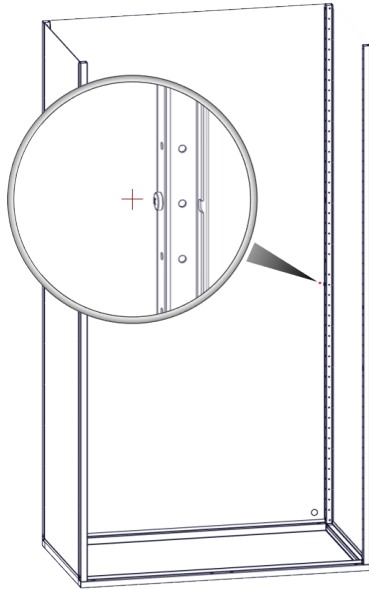
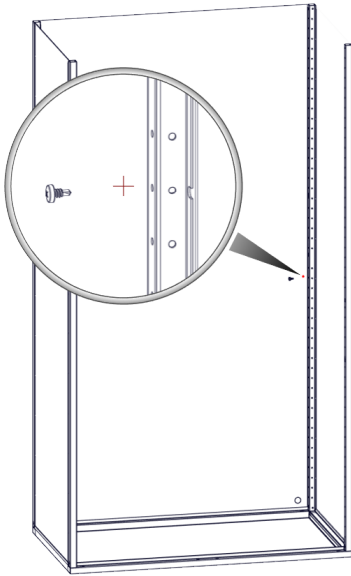

Locker bottom

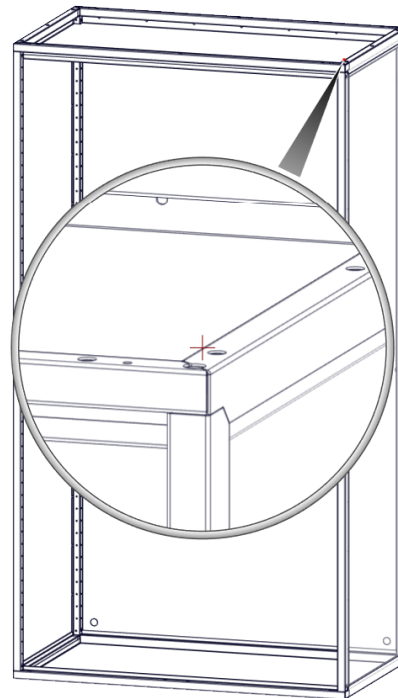
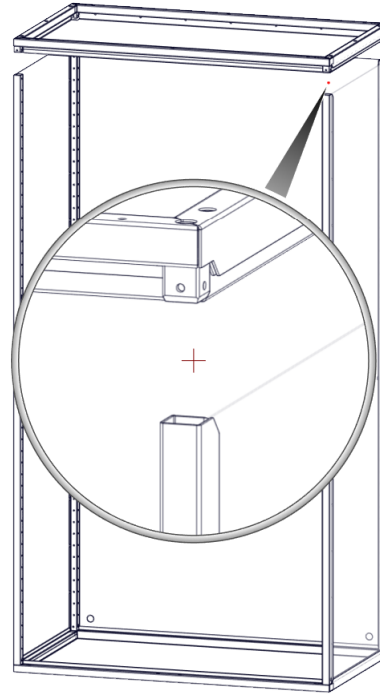

Fully Framed Patriot Turnout LOCKER – KD

Assembly Instructions



2C-2 Install one screw into each corner of the locker bottom as shown.

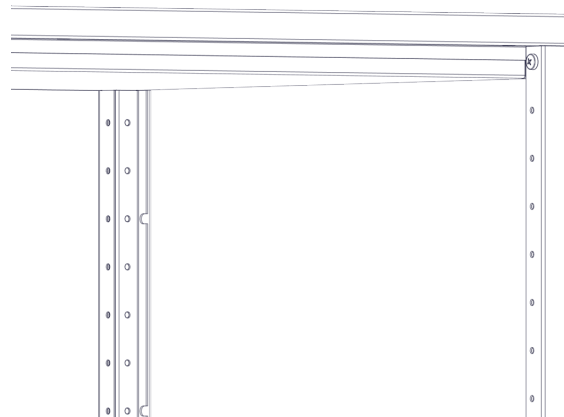
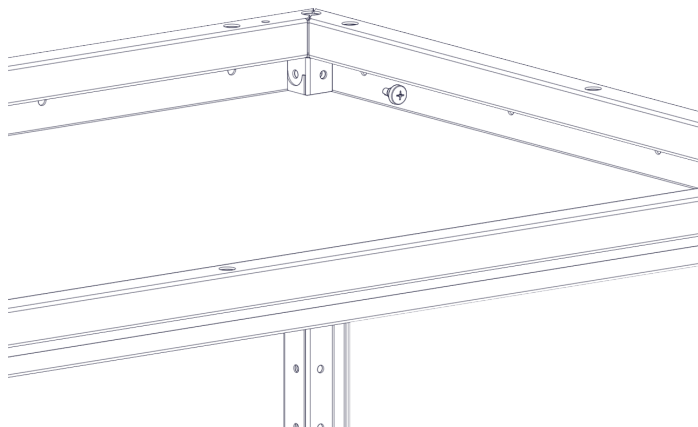
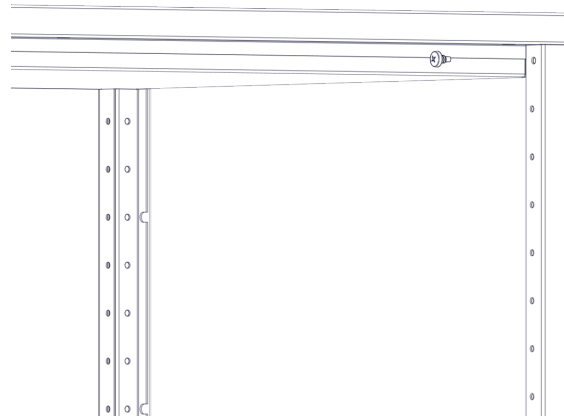
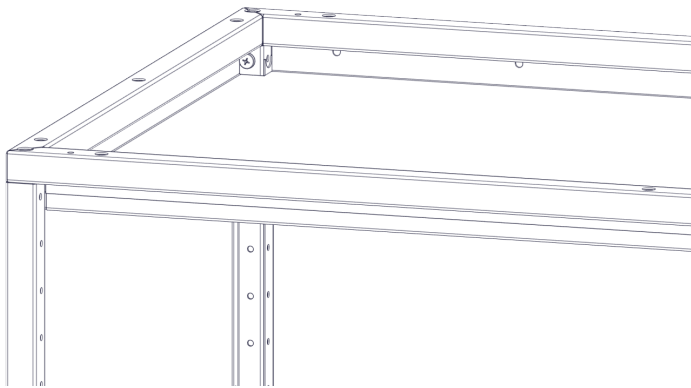
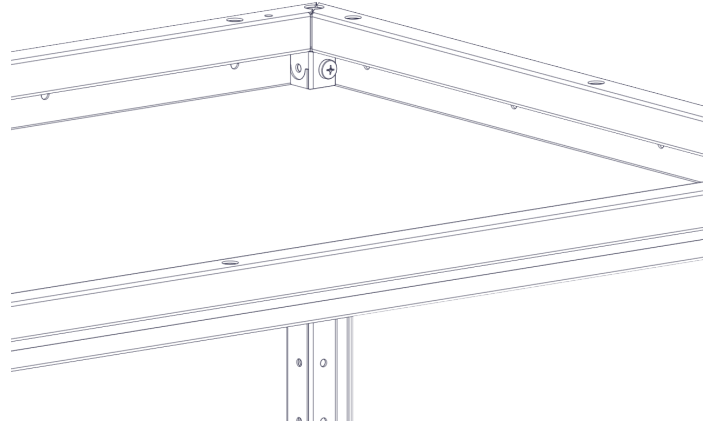
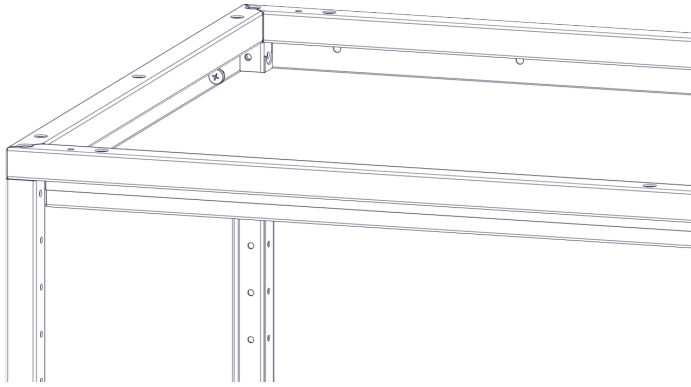

Fully Framed Patriot Turnout LOCKER – KD Assembly Instructions

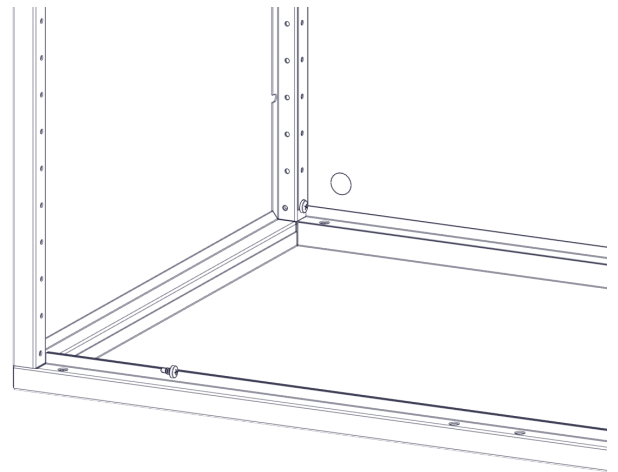
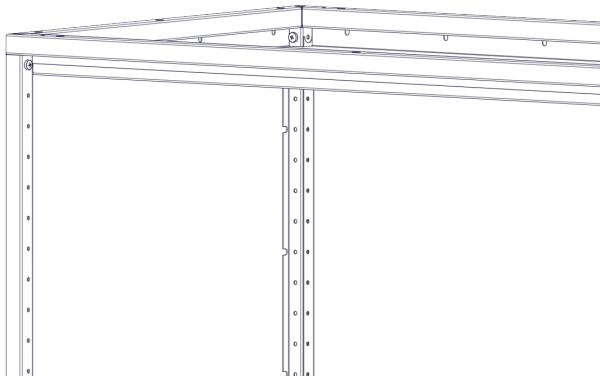
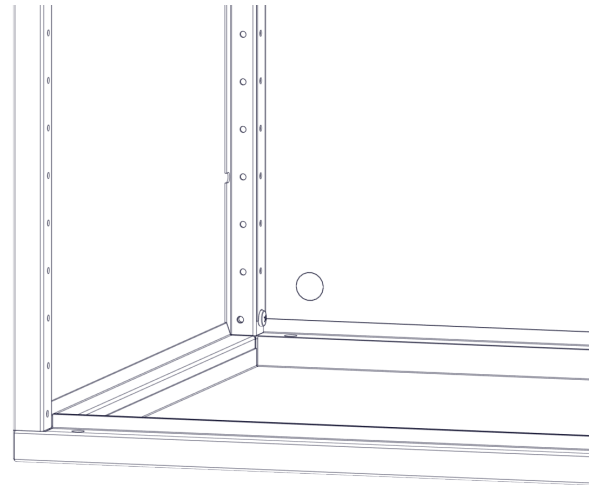
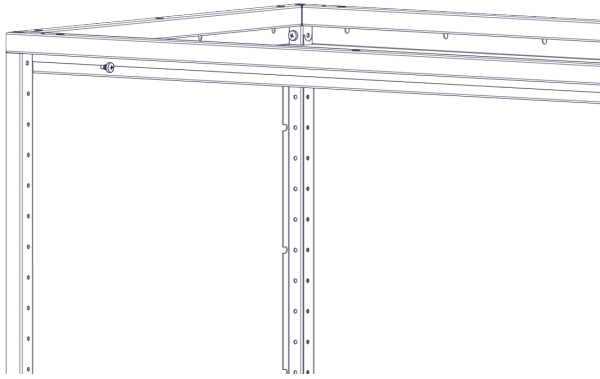

2D- Next install one screw into the locker top in each corner as shown.

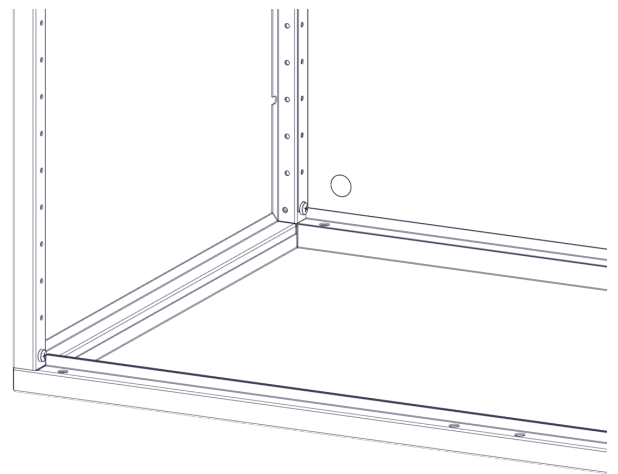
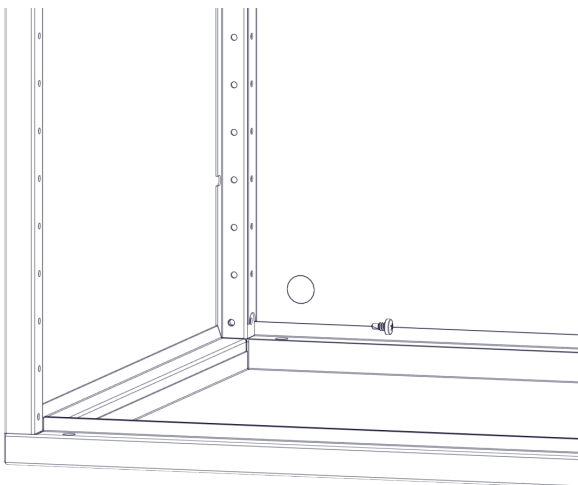

Fully Framed Patriot Turnout LOCKER – KD Assembly Instructions

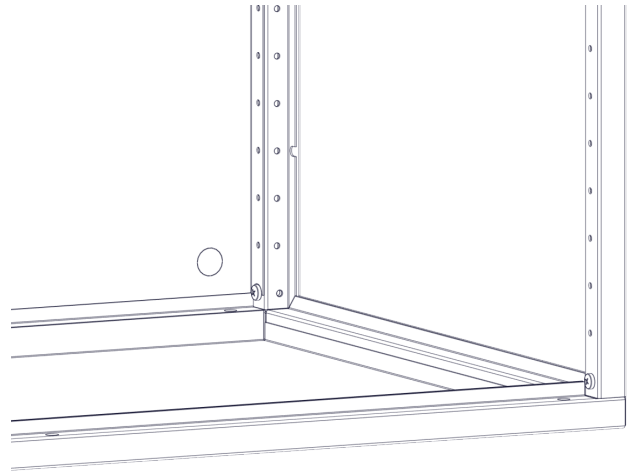
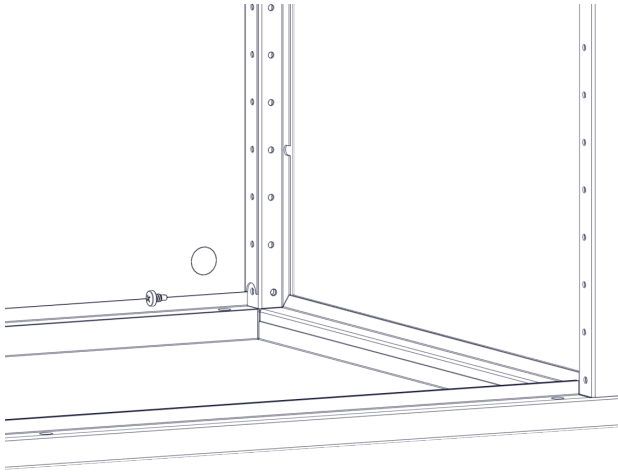

2E- Now rotate locker body so the bottom is on the ground.

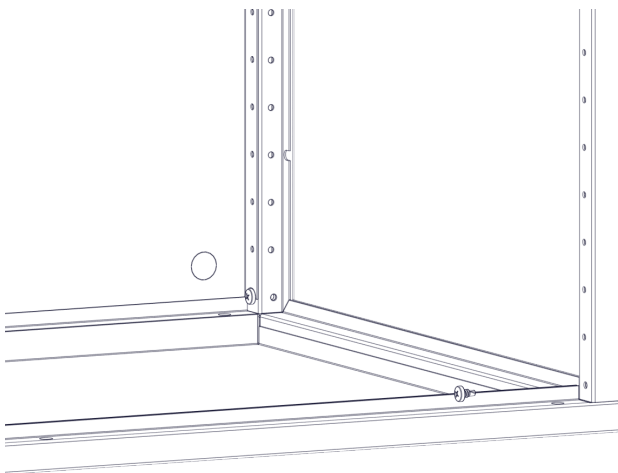
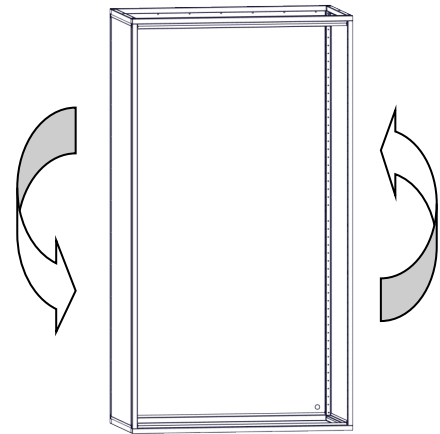
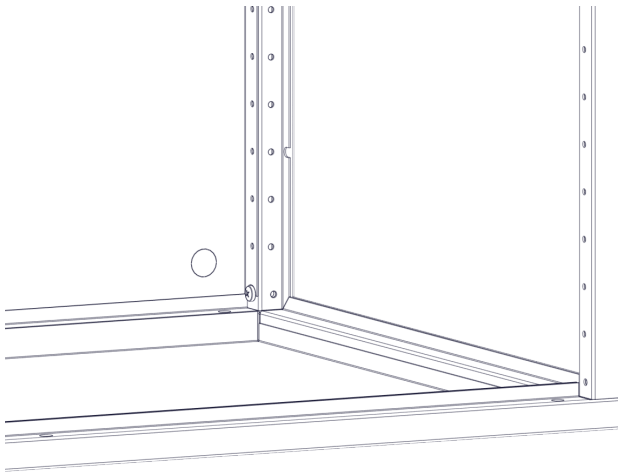

Fully Framed Patriot Turnout LOCKER – KD Assembly Instructions

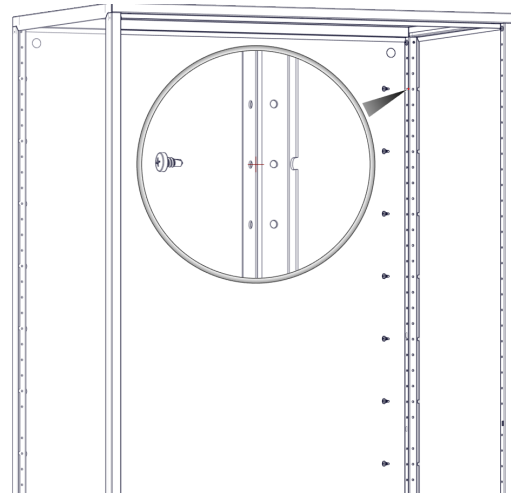
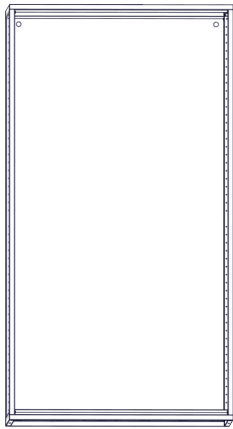
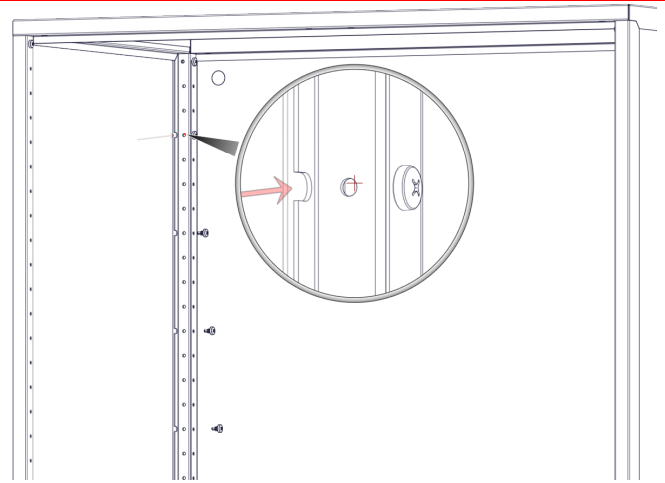
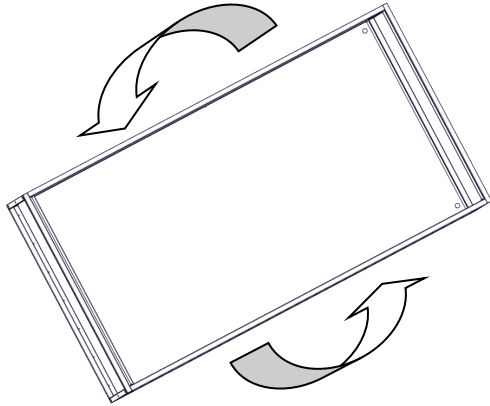

2F-Install screws to locker back at U cut locations (6-inch intervals) on each side.

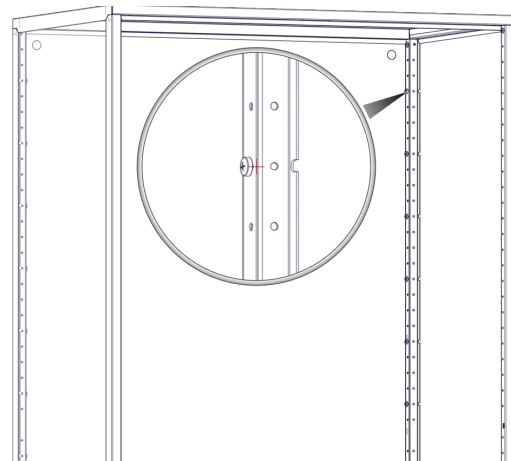
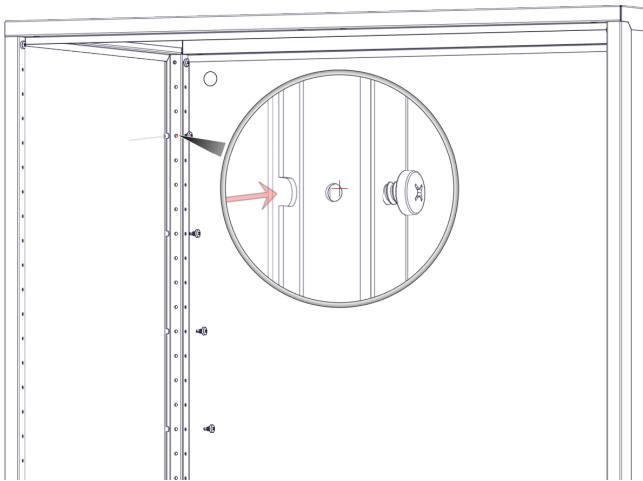

Fully Framed Patriot Turnout LOCKER – KD Assembly Instructions



Shell assembly is now complete. You can now add locker accessories. Lockers to be floor and wall anchored before use.

