

TYPICAL INSTALLATION

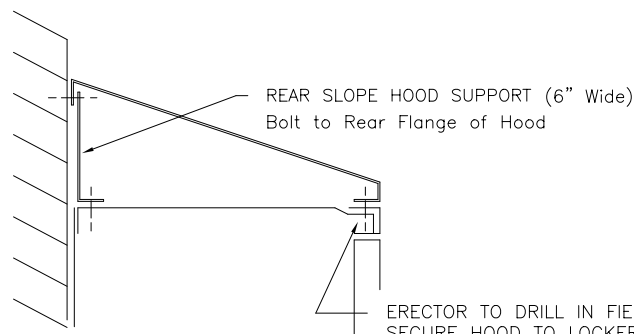

DETAIL OF SINGLE ROW SLOPE HOOD AT WALL

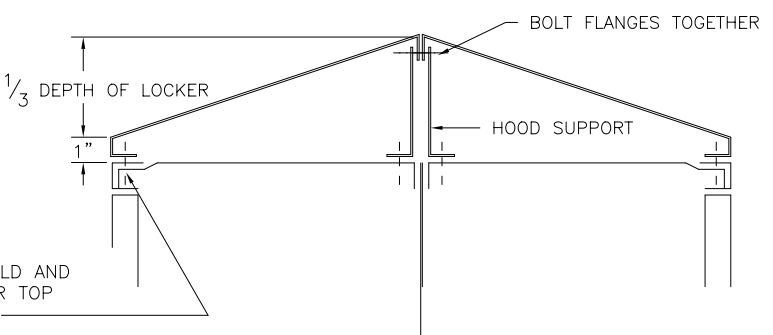

DETAIL OF DOUBLE ROW SLOPE HOOD

SLOPE HOOD INSTALLATION DETAILS

This drawing shows a standard Penco Product. Any modifications to the product must be approved by Penco Engineering. 8/6/2001

